



# The Intrepid Woodburning Stove

## Model 1640

### Homeowner's Installation and Operating Manual

For use in the United States and Canada

**SAFETY NOTICE: IF THIS APPLIANCE IS NOT PROPERLY INSTALLED, OPERATED AND MAINTAINED, A HOUSE FIRE MAY RESULT. TO REDUCE THE RISK OF FIRE, FOLLOW THE INSTALLATION INSTRUCTIONS. FAILURE TO FOLLOW INSTRUCTIONS MAY RESULT IN PROPERTY DAMAGE, BODILY INJURY OR EVEN DEATH. CONTACT LOCAL BUILDING OFFICIALS ABOUT RESTRICTIONS AND INSTALLATION INSPECTION REQUIREMENTS IN YOUR AREA.**

**NATIONAL FIREPLACE INSTITUTE**  
  
**CERTIFIED**  
[www.nficertified.org](http://www.nficertified.org)

We recommend that our woodburning hearth products be installed and serviced by professionals who are certified in the U.S. by the National Fireplace Institute® (NFI) as NFI Woodburning Specialists or who are certified in Canada by Wood Energy Technical Training (WETT).

 **Wood Energy Technical Training**  
[www.wettinc.ca](http://www.wettinc.ca)

### CFM Specialty Home Products

410 Admiral Blvd. • Mississauga, Ontario, Canada L5T 2N6 • 905-670-7777  
[www.majesticproducts.com](http://www.majesticproducts.com) • [www.vermontcastings.com](http://www.vermontcastings.com)

**Do Not Discard This Manual: Retain for Future Use**

# Introduction

Thank you for choosing a Vermont Castings Intrepid to meet your heating needs. We're confident you will find the Intrepid to be an effective wood-burning heater incorporating modern, non-catalytic combustion technology with the classic aesthetic appeal of its Vermont Castings lineage.

The Intrepid achieves high-efficiency through precisely calibrated delivery of primary and secondary air into a refractory-insulated firebox. Properly operated and maintained according to the guidelines in this manual, your Intrepid will provide safe, dependable, and economical heating for years to come.



The Intrepid Model 1640 series has been tested and is listed by the Canadian Standards Association (CSA). The test standards are ANSI/UL-1482 for the United States and ULC S627 and CAN/CSA B366.2 for Canada.

The Intrepid Model 1640 is listed for burning wood fuel only. Do not burn other fuels.

**C US** The Intrepid Model 1640 is approved for installation in manufactured (mobile) homes in the United States only using the optional Mobile Home Kit #1881 in accordance with the instructions in that kit and any local codes.

The Intrepid Model 1640 complies with the standards set forth by the Federal Environmental Protection Agency, 40 CFR Part 60.532(b)(2), as stated on the permanent label attached to each stove.

We recommend that you hire a professional, solid-fuel stove technician to install your Intrepid, or to advise you on the installation should you attempt to install it yourself. Consult the authority having local jurisdiction (such as a municipal building department, fire department, fire prevention bureau, etc.) before installation to determine the need for a building permit. Also, consult your insurance agent to be sure your installation complies with specific requirements that may vary locally.

In addition to directions on installation and operation, this manual includes directions on maintenance and assembly. Please read this entire manual before you install or operate your new room heater.

**Save These Instructions For Future Reference.**

**Proposition 65 Warning:** Fuels used in gas, wood-burning or oil fired appliances, and the products of combustion of such fuels, contain chemicals known to the State of California to cause cancer, birth defects and other reproductive harm.  
California Health & Safety Code Sec. 25249.6

## Table of Contents

Specifications .....	3
Installation Requirements .....	4
Clearances .....	14
Assembly .....	16
Operation.....	18
Maintenance .....	22
Appendix - Draft Management .....	25
Parts List .....	28

## Installation Accessories

- #1878 Outside Air Kit
- #1881 Mobile Home Kit
- #0307 Bottom Heat Shield
- #0868 Short Legs - Classic Black
- #1515 Short Legs - Red
- #1512 Short Legs - Sand
- #1520 Short Legs - Moonlight Blue
- #1510 Short Legs - Green
- #0136 Sparkscreen
- #0098 Warming Shelf - Classic Black
- #1355 Warming Shelf - Red
- #1362 Warming Shelf - Sand
- #1363 Warming Shelf - Moonlight Blue
- #1365 Warming Shelf - Forest Green

# Specifications

## Intrepid, Model 1640

Maximum Heat Output .....8,200 - 19,500 Btu's/hr.<sup>3</sup>  
 Maximum Heat Output ..... 22,00 Btu's/hr.<sup>1</sup>  
 Area Heated .....Up to 1000 sq. ft.(92 sq. m)<sup>2</sup>  
 Fuel Size / Type..... 16" (410 mm) logs  
 EPA Emissions Rating (g/h, non-catalytic) .....3.3<sup>3</sup>  
 LoadingFront  
 Chimney Connector..... 6" (150 mm) diameter  
 Chimney Flue Size .....6" (150 mm) minimum  
 Flue Exit Position..... Reversible, Top or Rear  
 Primary Air... Manually set, thermostatically maintained  
 Secondary Air ..... Self-regulating  
 Ash Handling System ..... Removable Ash Pan  
 Glass Panels .....High-temp Ceramic, IR Coated  
 Weight 255 lbs. (116kg.)

Height to top of flue collar:

With regular legs.....25¼" (630mm) top exit  
 ..... 24" (610mm) rear exit  
 With optionalshort legs .21¼" (540mm) top exit  
 ..... 20" (510mm) rear exit

<sup>1</sup> This value can vary depending on how the stove is operated, the type and moisture content of the fuel used, as well as the design, construction and climatic location of your home. Figures shown are based on maximum fuel consumption obtained under laboratory conditions and on average efficiencies.

<sup>2</sup> These values are based on operation in building code-conforming homes under typical winter climate conditions in New England. If your home is of nonstandard construction (e.g., unusually well insulated, not insulated, built under ground, etc.) or if you live in a more severe or more temperate climate, these figures may not apply. Since so many variables affect performance, consult your Vermont Castings authorized dealer to determine realistic expectations for your home.

<sup>3</sup> Under specific conditions used during EPA emissions testing.

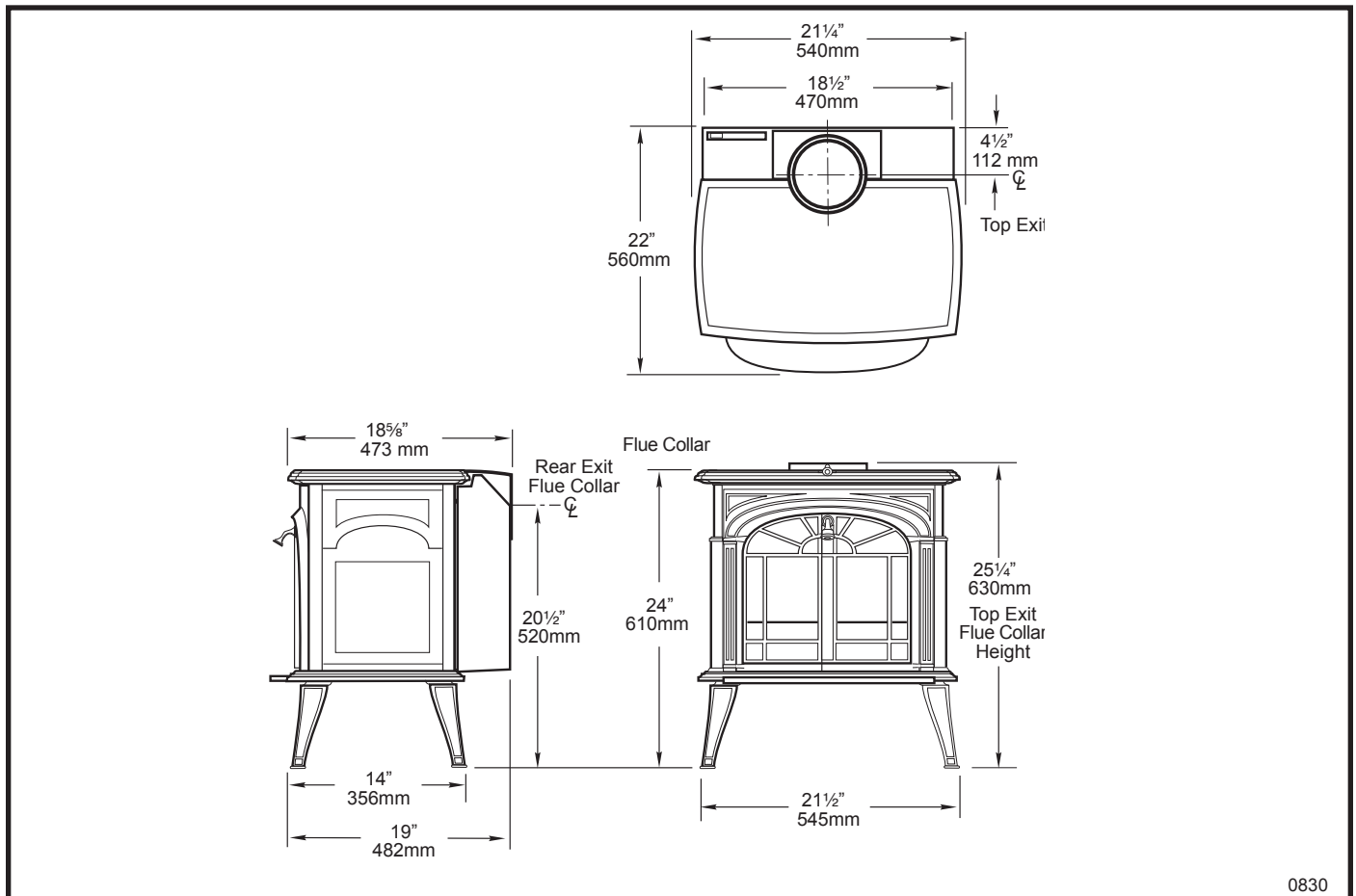

Fig. 1 Intrepid 1640 dimensions.

## Installation

**SAFETY NOTICE: IF YOUR STOVE IS NOT PROPERLY INSTALLED, OPERATED AND MAINTAINED, A HOUSE FIRE MAY RESULT. FOR SAFETY, FOLLOW ALL INSTALLATION, OPERATION AND MAINTENANCE DIRECTIONS. CONTACT LOCAL BUILDING OFFICIALS ABOUT RESTRICTIONS AND IN□.**

Before you begin an installation, review your plans to be certain that:

- Your stove and chimney connector will be far enough from combustible material to meet all clearance requirements.
- The floor protector is large enough and is constructed properly to meet all requirements.
- You have all necessary permits from local authorities.

Your local building official is the final authority for approving your installation as safe and determining that it meets local and state codes.

The metal label permanently attached to the back of the stove indicates that the Intrepid has been tested to current UL and ULC standards by CSA. Clearance and installation information is also printed on the label. Local authorities generally will accept the label as evidence that, when the stove is installed according to the information on the label and in this manual, the installation meets codes and can be approved. Codes, however, vary in different areas. Before starting the installation, review your plans with the local building authority. Your local dealer can provide any additional information needed.

For any unresolved questions about installation, refer to the National Fire Protection Association's publication ANSI/NFPA 211–1988 Standard for Chimneys, Fireplaces, Vents and Solid Fuel Burning Appliances. In Canada, the equivalent publication is CSA CAN-B365, Installation Code for Solid Fuel Burning Appliances and Equipment. These standards are the bases for many national codes. They are nationally recognized and are accepted by most local authorities. Your local dealer or your local building official may have a copy of these regulations.

**IMPORTANT: FAILURE TO FOLLOW THESE INSTALLATION INSTRUCTIONS MAY RESULT IN A DANGEROUS SITUATION, INCLUDING A CHIMNEY OR HOUSE FIRE. FOLLOW ALL INSTRUCTIONS EXACTLY AND DO NOT ALLOW MAKESHIFT COMPROMISES TO ENDANGER PROPERTY AND PERSONAL SAFETY.**

### Chimneys

Your stove must be connected either to a sound masonry chimney that meets local codes, to a relined masonry chimney that meets local codes, or to an approved prefabricated metal chimney. Whichever of those types you use, the chimney and chimney connector must be in good condition and kept clean.

If you use an existing masonry chimney, it must be inspected to ensure safe condition before the stove is installed. Your local professional chimney sweep, building inspector, or fire department official will be able to make the inspection or direct you to someone who can.

The chimney should extend at least 3' (914mm) above the highest point where it passes through a roof, and at least 2' (610mm) higher than any portion of a building within 10' (3m).

To assure proper draft and good performance, any chimney used with this stove should extend at least 16' (5 m) above the flue collar of the stove.

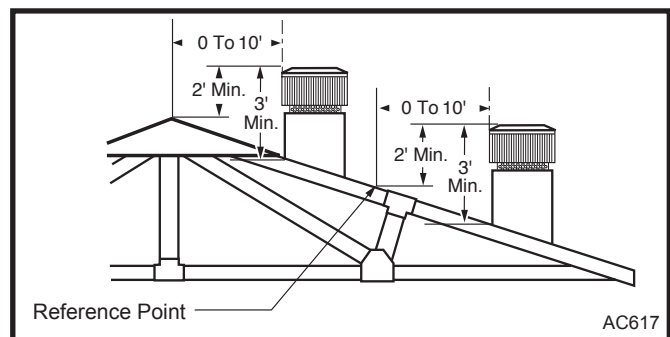

**Fig. 2** The 2'-3'-10' Chimney Rule.

### Masonry Chimneys

An existing masonry chimney must be inspected to confirm that it has a lining. Do not use an unlined chimney. The chimney also should be examined for cracks, loose mortar, other signs of deterioration, and blockage. Repair any defects before the chimney is used with your stove.

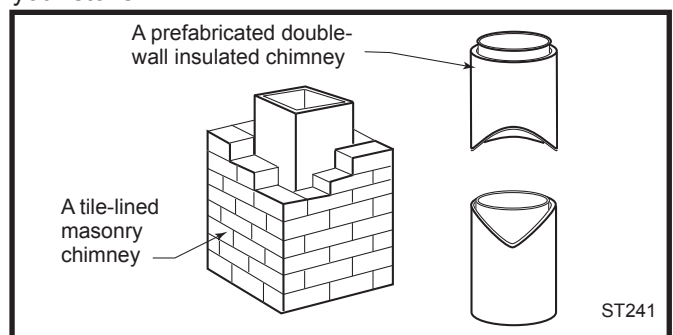

**Fig. 3** Standard Chimney Types

### Masonry Chimneys, cont'd.

- Unused openings in an existing masonry chimney must be sealed with masonry to the thickness of the chimney wall, and the chimney liner should be repaired. Openings sealed with pie plates or wallpaper are a hazard and should be sealed with mortar or refractory cement. In the event of a chimney fire, flames and smoke may be forced out of these unused thimbles.
- The chimney should be thoroughly cleaned before use.
- A newly-built masonry chimney must conform to the standards of local building code, or, in the absence of a local code, to a recognized national code. Masonry chimneys must be lined, either with code-approved masonry or precast refractory tiles, stainless steel pipe, or a code-approved, "poured-in-place" liner. The chimney clean-out door must seal tightly to ensure a good draft.

### Prefabricated Chimneys

A prefabricated metal chimney must be one that is tested and listed for use with solid-fuel burning appliances to the High-Temperature (H.T.) Chimney Standard UL-103-1985 (2100°F.) for the United States, and High Temperature (650°C) Standard ULC S-629 for Canada.

### Chimney Size

This stove is approved for venting into a masonry chimney with a nominal flue size of 8" x 8" (203 x 203mm), and into a round flue size of 8" (203mm) or 6" (152mm).

It may be vented into larger chimneys as well. However, chimneys with liners larger than 8" x 12" (203 x 305mm) may experience rapid cooling of smoke and reduction in draft, especially if they are located outside the home. Such large chimneys may need to be insulated or have the flue relined for proper stove performance.

**Do not connect this unit to a chimney flue serving another appliance.**

**Note: Do not vent this stove into a factory-built (zero-clearance) fireplace. This stove has not been tested and listed for that type of installation. Factory-built fireplaces and their chimneys are specifically designed as a unit for use as fireplaces. It may void the listing or be hazardous to adapt them for any other use.**

**Do not connect the STOVE to any air distribution duct or system.**

Ask your dealer about components available for connecting the stove to a steel chimney liner.

### Chimney Connector Guidelines

A chimney connector is the double-wall or single-wall pipe that connects the stove to the chimney. The chimney itself is a masonry or prefabricated structure that encloses the flue. Chimney connectors are used only to make the connection from the stove to the chimney. They are for interior use only.

Double-wall connectors must be tested and listed for use with solid-fuel burning appliances. Single-wall connectors should be made of 24 gauge or heavier steel, and should be 6" (152mm) in diameter. Do not use galvanized chimney connector; it cannot withstand the high temperatures that can be reached by smoke and exhaust gases, and may release toxic fumes under high heat.

If possible, do not pass the chimney connector through a combustible wall or ceiling. If passage through a combustible wall is unavoidable, refer to the recommendations in the section following on Wall Pass-throughs. Do not pass the connector through an attic, a closet or any similar concealed space. The whole chimney connector should be exposed and accessible for inspection and cleaning.

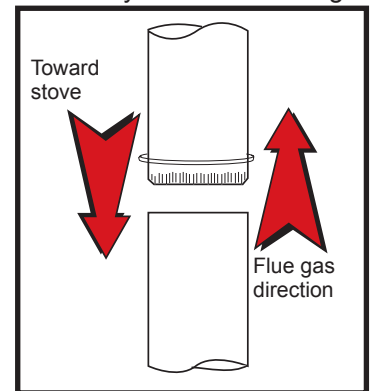

Fig. 4. Chimney connector.

Install the single wall chimney connector not less than 18" (457mm) from the ceiling. Keep it as short and direct as possible, with no more than two 90° turns. If possible, use 45° elbows. Slope horizontal runs of connectors upward 1/4" per foot (20 mm per meter) going from the stove toward the chimney. The recommended maximum length of a horizontal run is 3 feet (1 meter), and the total length of chimney connector should be no longer than 8' (2.4meters).

In cathedral ceiling installations, extend the prefabricated chimney downward to within 8' (2.4m) of the stove.

**SAFETY NOTE: ALWAYS WEAR GLOVES AND PROTECTIVE EYEWEAR WHEN DRILLING, CUTTING OR JOINING CHIMNEY CONNECTOR SECTIONS .**

## Double-wall Chimney Connectors

The Intrepid is approved for installation in the U.S. and Canada with double-wall chimney connectors that have been tested and listed for use with solid-fuel burning appliances by a recognized testing laboratory.

Follow the instructions for assembling and installing double-wall connectors provided by the manufacturer of the double-wall chimney. To ease assembly and help assure safety, use chimney components manufactured by a single source.

**NOTE: For installations using double-wall connectors, minimum clearances must conform to those listed in the clearance chart on Page 14.**

## Single-wall Chimney Connectors

- Beginning at the flue collar of the stove, assemble the chimney connector. Insert the first crimped end into the stove's flue collar, and keep each crimped end pointing toward the stove. Using the holes in the flue collar as guides, drill 1/8" (3mm) holes in the bottom of the first section of chimney connector and secure it to the flue collar with three #10 x 1/2" sheet metal screws.
- Secure each joint between sections of chimney connector, including telescoping joints, with at least three sheet metal screws. The predrilled holes in the top of each section of chimney connector serve as guides when you drill 1/8" (3mm) holes in the bottom of the next section.
- Secure the chimney connector to the chimney. Instructions for various installations follow.
- Be sure the installed stove and chimney connector are correct distances from nearby combustible material.

**Note:** Special slip pipes and thimble sleeves that form telescoping joints between sections of chimney connector are available to simplify assembly. Slip pipes eliminate the need to cut individual connector sections. Consult your local dealer about these special connector sections.

## Securing the Single-wall Connector to a Prefabricated Chimney

Follow the installation instructions of the chimney manufacturer exactly.

Special adaptors are available from your local dealer to make the connection between the prefabricated chimney and the chimney connector. The top of such adaptors attach directly to the chimney or to the chimney's ceiling support package. The bottom of the adaptor is secured to the chimney connector.

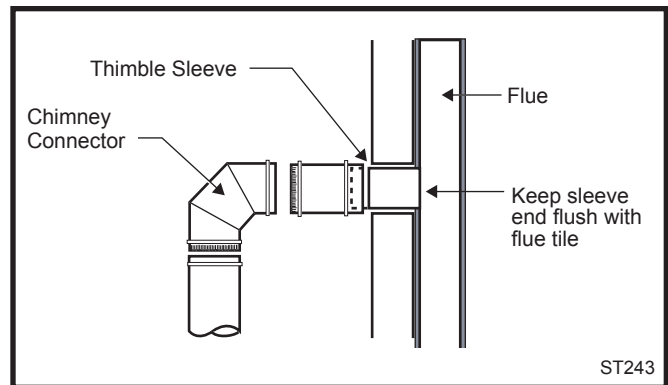

**Fig. 6** The thimble, made of either ceramic or metal, must be cemented securely in place.

The adapter forms a union between the chimney and chimney connector that ensures any soot or creosote falling from the inner walls of the chimney will stay inside the chimney connector.

## Securing the Single-wall Connector to a Masonry Chimney

The Intrepid may be connected to either a freestanding masonry chimney or to a fireplace masonry chimney.

### Freestanding Installations

If the chimney connector must pass through a combustible wall to reach the chimney, follow the recommendations for Wall Pass-Through construction on Pages 7-8.

The opening through the chimney wall to the flue - the "breach" - must be lined with a ceramic or metal thimble which is securely cemented in place.

A metal pipe section called the "thimble sleeve," slightly smaller in diameter than standard connector and the thimbles, will allow the removal of the chimney connector system for inspection and cleaning. Thimble sleeves are available from your local dealer.

To install a thimble sleeve, slide it into the breach until it is flush with the inner flue wall. Be sure that it does not extend into the flue passage where it could interfere with the draft.

The thimble sleeve should protrude 1-2" (25-50mm) into the room. Use furnace cement and thin gasketing to seal the sleeve in place in the thimble. Secure the chimney connector to the outer end of the sleeve with sheet metal screws.

## Connection Above the Fireplace

In this installation, the chimney connector enters the fireplace flue through a thimble located above the fireplace. The liner of the fireplace chimney should extend at least to the point at which the chimney connector enters the chimney. Follow all the guidelines for installing a chimney connector into a freestanding masonry chimney, and pay special attention to these additional points:

- Check the stove and chimney connector clearances to combustible mantel and trim materials. If necessary, use a combination of mantel, trim, and connector heat shields to provide the required clearances. Refer to Page 12.
- Double-check connector clearance to the ceiling.
- The fireplace damper must be closed and sealed to prevent room air from being drawn up the flue which could reduce performance. However, it must be possible to reopen the damper to inspect or clean the chimney.
- Floor protection requirements also apply to fireplace installations. Refer to Page 8.

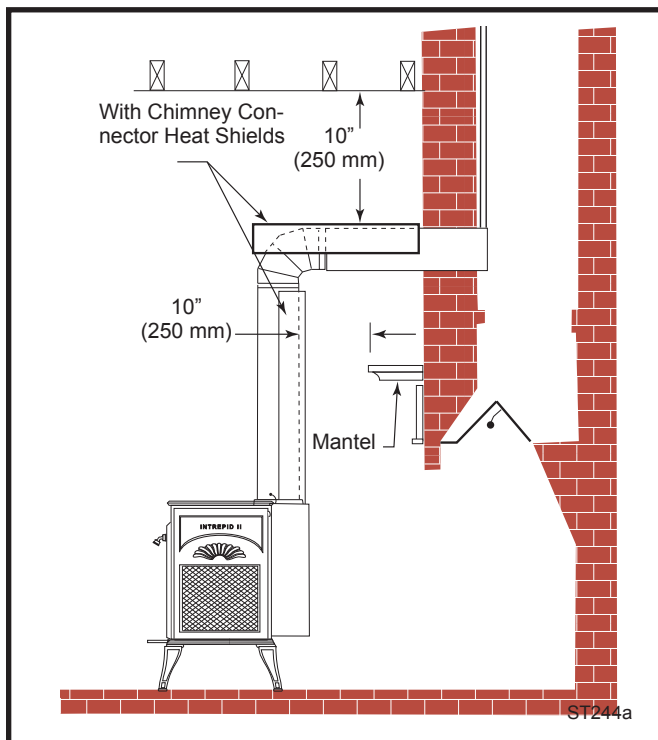

**Fig. 7** If the clearance between the chimney connector and either the ceiling or the mantel is inadequate, a protective heat shield is required.

## Wall Pass-throughs

Whenever possible, design the installation so that the connector does not pass through a combustible wall. If you must include a wall pass-through in your installation, check with your building inspector before you begin. Also check with the chimney connector manufacturer for any specific requirements.

Consult with your dealer regarding special connection components available for use as wall pass-throughs. Use only parts that have been tested and listed for use as a wall pass-through. Refer to Figures 9 - 12 for further details.

### U.S. Requirements:

The National Fire Protection Association (NFPA) has established guidelines for use in the United States for passing chimney connectors through combustible walls. Many building code inspectors follow these guidelines.

Figure 9 shows one NFPA-approved method. All combustible material in the wall is cut away to provide 12" (305mm) clearance to the connector. Brick and mortar are used to enclose the clearance area.

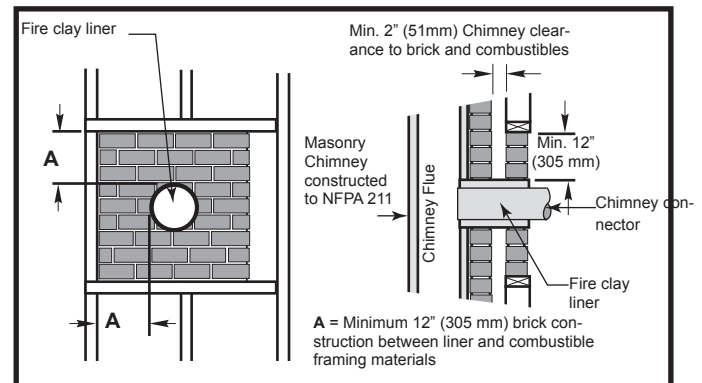

**Fig. 9** Masonry Wall Pass-through with single wall chimney connector.

### Alternate Methods Approved by the NFPA:

- Using a section of double-wall chimney with a 9" (229mm) clearance to combustibles. (Fig. 10)
- Placing a chimney connector pipe inside a steel double-wall ventilated thimble, which is then separated from combustibles by 6" (152mm) of fiberglass insulating material. (Fig. 11)
- Placing a chimney connector pipe inside a section of 9" (229mm) diameter, solid-insulated, factory-built chimney, with two inches of air space between the chimney section and combustibles. (Fig. 12)

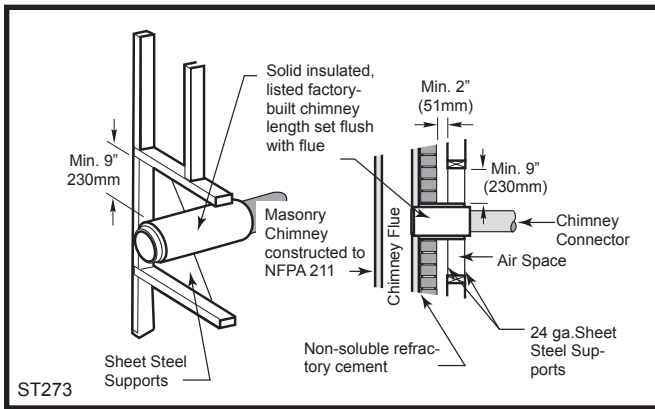

**Fig. 10** Wall Pass-through using factory-built insulated chimney section.

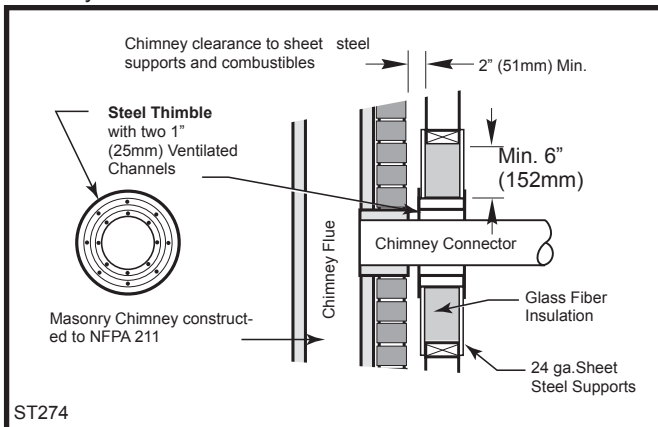

**Fig. 11** Wall Pass-through using single wall chimney connector with a ventilated steel thimble.

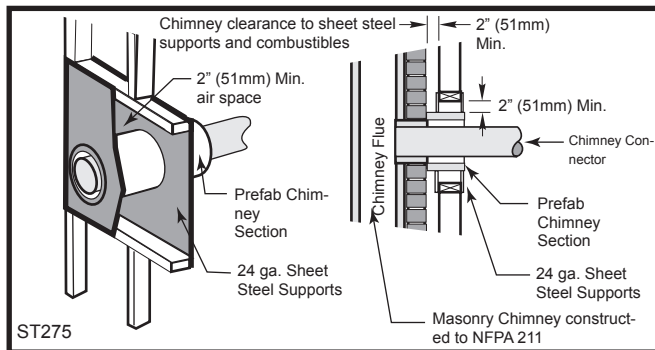

**Fig. 12** Wall Pass-through with ventilated steel thimble.

**Canadian Requirements:**

In Canada, the Canadian Standards Association has established specific guidelines regarding wall pass-through design. Figure 13 shows one approved method in which all combustible material in the wall is cut away to provide the required 18" (457mm) clearance around the connector. The resulting space must remain empty. A flush-mounted sheet metal cover may be used on one side only. If covers must be used on both sides, each cover must be mounted on noncombustible spacers at least 1" (25mm) clear of the wall. Your local dealer or

your local building inspector can provide details of other approved methods of passing a chimney connector through a combustible wall.

In Canada, this type of installation must conform to CAN/CSA-B365, Installation Code for Solid Fuel Burning Appliances and Equipment.

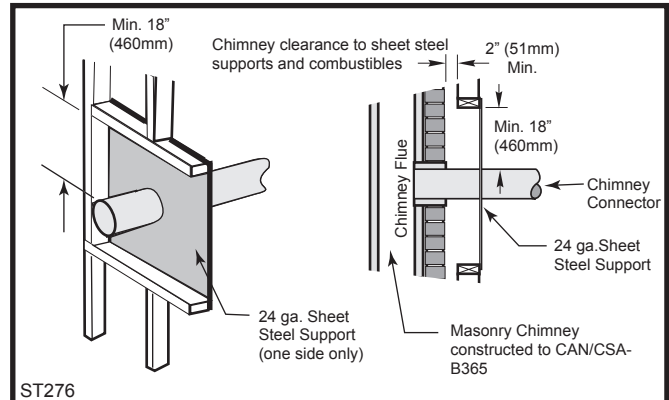

**Fig. 13** CSA approved Wall Pass-through.

**Floor Protection**

A tremendous amount of heat radiates from the bottom plate of an Intrepid II, and the floor beneath requires two kinds of special protection.

Heat protection is provided by a Vermont Castings Bottom Heat Shield, part #0307.

Spark and ember protection is provided by a floor protector, which may be any noncombustible material.

For a new hearth, we recommend a noncombustible floor protector such as 1/4" non-asbestos mineral board or its equivalent, or 24 gauge sheet metal. If carpeting is present, it must be removed before installation of the floor protector. The floor protector may be covered with a noncombustible decorative material if desired. When using brick, tile, or stone, individual pieces must be mortared so sparks cannot fall through.

When the optional 3" (75mm) short legs are used, the bottom heat shield must be used.

**Most installations will require that the bottom heat shield be attached. Only when the stove is placed on a completely noncombustible surface, such as unpainted concrete over earth, may it be used without the bottom heat shield.**

Even with the bottom heat shield installed, you must also use a floor protector.

**In the United States**, the floor protector required under the stove must extend at least 16" from the front of the stove - not from the ashlip - ('E' in Fig. 14), and at least 6" from the sides and rear ('D', Fig. 14).

To meet the requirement in the United States, a floor protector must be at least 34" wide and 40" deep.

**In Canada**, the floor protector required under the stove must extend 18" (457mm) to the front ('E', Fig. 14), and 8" (203mm) from the sides and rear. ('D', Fig. 14)

To meet Canadian requirements, a floor protector must be at least 43" (1092mm) wide and 48" (1219mm) deep.

Floor protection also must extend under the chimney connector and 2 inches to either side. ('C', Fig. 14)  
For 6" (152mm) connector used with the Intrepid II, the protector must be a minimum of 10" (254mm) wide, centered under the connector.

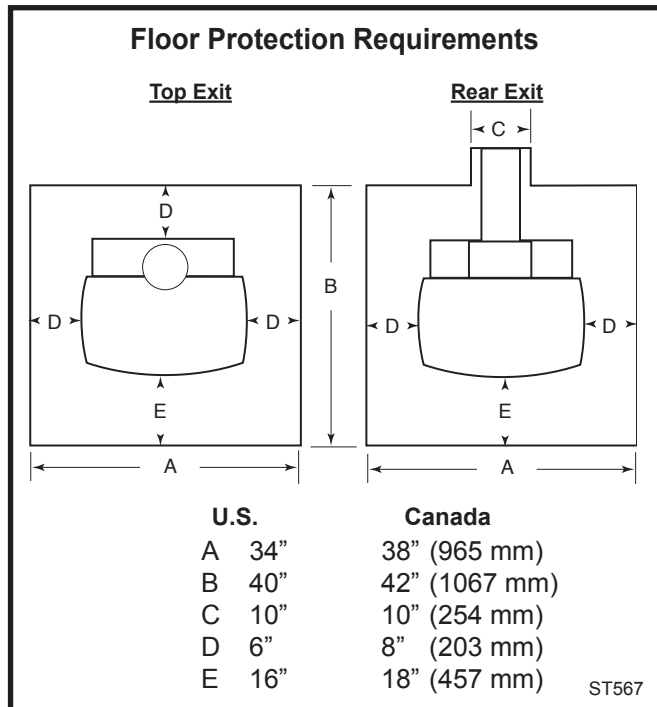

**Fig. 14** These dimensions are minimum requirements only. Use greater dimensions whenever possible.

### Fireplace Hearth Protection

Do not assume that your fireplace hearth is completely noncombustible. Many fireplace hearths do not satisfy the "completely noncombustible" requirement because the brick or concrete in front of the fireplace opening is supported by heavy wood framing. Because heat is readily conducted by brick or concrete, it can easily pass through to the wood. As a result, such fireplace hearths can be a fire hazard and are considered a combustible floor.

For all fireplace installations, follow the floor protection guidelines described above.

Keep in mind that many raised hearths will extend less than the required clearance from the front of the heater when it is installed. In such cases, sufficient floor protection as described above must be added in front of the hearth to satisfy the minimum floor protector requirement from the front of the stove: 16" (416 mm)

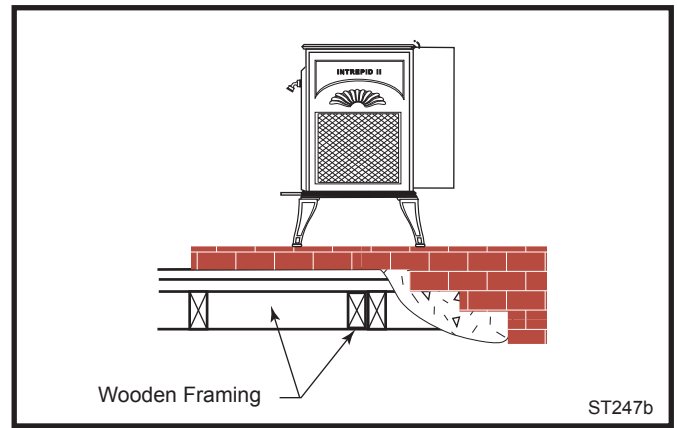

**Fig. 15** Supporting timbers under fireplace hearths are considered to be combustible.

from the front in the United States and 18" (457 mm) from the front in Canada.

The optional 3" (75 mm) legs may be used only on hearths that meet the width and depth requirements.

Hearth rugs do not satisfy the requirements for floor protection as they are only fire-retardant, not fire proof.

### Mobile Home Installation

The Intrepid is approved for use in manufactured (mobile) homes when installed with the optional Vermont Castings Mobile Home Kit #1881 in accordance with the instructions provided with that kit and any local codes. This approval applies only in the United States.

In addition to the standard installation requirements described in this manual, the following guidelines apply to mobile home installations:

1. The stove must be permanently secured to the floor using the leg clamps and fasteners provided in the kit.
2. The stove must have a permanent connection to the outside to supply combustion air.
3. The stove must be grounded to the steel chassis of the mobile home.
4. A listed chimney system, including roof thimble, spark arrester, chimney supports, roof flashing and any other components suitable for use in mobile homes must be used. The chimney system must comply with the standard for Chimneys Factory-Built Residential Type and Building Heating Appliances UL 103.
5. The chimney must be attached directly to the stove and must extend at least 3' (914 mm) above the part of the roof through which it passes. The top of the chimney must extend at least 2' (610 mm) above the highest point of any part of the mobile home structure within 10' (3 m) of the chimney.

6. If the chimney exits the mobile home through a wall at a point 7' (2.1 m) or less above the ground level on which the mobile home is located, a guard or other noncombustible enclosure must be fitted at the point of exit and extend up to a height of 7' (2.1m). Any openings in this guard must be smaller than 3/4" (19mm).
7. Check all local building codes, specifically those related to mobile homes. Other requirements may be applicable to chimney system removal for transportation of the mobile home.

**WARNING: Do not install the Intrepid in a sleeping room or hallway.**

**CAUTION: The structural integrity of the mobile home roof, floor, walls and ceiling must be maintained.**

### Clearance to Surrounding Combustible Materials

When the stove is operating, both the stoveplate and the chimney connector radiate heat in all directions. A safe installation requires that adequate clearance be maintained between the stove and nearby combustible materials to ensure that those materials do not over-heat.

Clearance is the distance between either your stove or chimney connector, and nearby walls, floors, the ceiling, and any other fixed combustible surface. **Keep furnishings and other combustible materials away from the stove as well.** In general, a distance of 48" (1219mm) must be maintained between the stove and moveable combustible items such as drying clothes, furniture, newspapers, firewood, etc. Keep this area empty of any combustible material.

### Safe Ways To Reduce Clearances

The Intrepid clearance requirements, listed and diagramed on Pages 14-15, have been established through testing to UL and ULC standards to meet most installation configurations. These involve four basic variables:

- When the stove has no listed heat shield installed.
- When the stove does have a listed heat shield mounted on it.
- When the wall has no listed heat shield installed.
- When the wall does have a listed heat shield mounted on it.

In general, the greatest clearance is required when the stove will be positioned with no heat shield near a wall with no heat shield. The least clearance is required when both the stove and the wall have heat shields.

Reducing a stove clearance may require installation of a listed heat shield on the chimney connector as well.

Clearances may be reduced only by means approved by the regulatory authority, or in accordance with the clearances listed in this manual.

When determining clearance, always measure from the top plate of the stove, or, from the chimney connector itself, to the adjacent combustible surface. Do not measure from the heat shields of the stove or connector to the combustible surface.

### Wall Shields

Wall shields should be constructed of 24 gauge or heavier sheet metal, or another noncombustible material such as 1/2" (13mm) insulation board or common brick "laid on flat," with the 3 1/2" (89mm) side down.

Shields must be spaced out from the combustible surface 1" (25mm) on noncombustible spacers. The spacers should not be directly behind the stove or chimney connector. (Fig. 16)

Air must be able to flow between the wall and the shield. At least 50% of the bottom 1" (25mm) of the shield should be open and the shield must be open at the top.

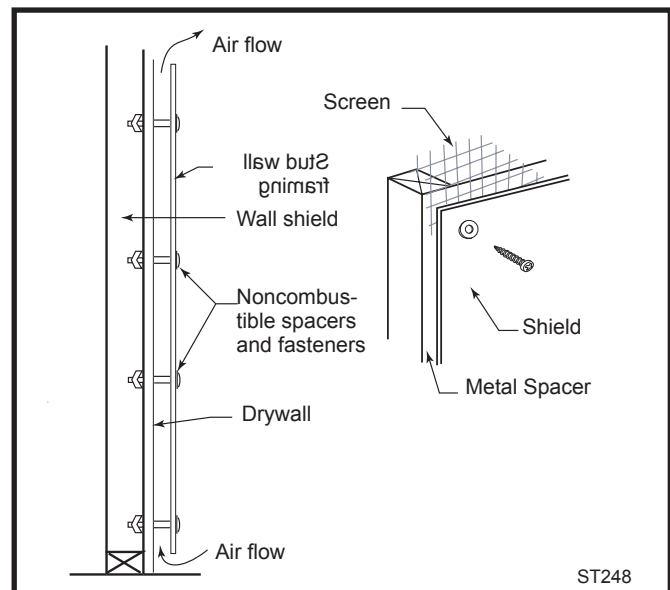

**Fig. 16** Approved Wall shield construction

The following examples of wall shield construction illustrate common designs used to safely achieve reduced clearances to combustible wall materials.

**Parallel installation, vertical chimney connector, two wall shields.** Fig. 17: Reduced clearances for both rear and side walls. Wall shields may meet at corner if desired. Shielding for connector is centered behind connector.

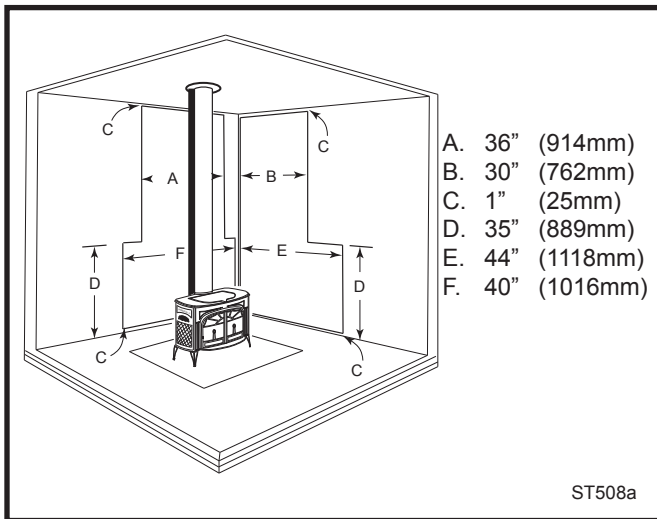

- A. 36" (914mm)
- B. 30" (762mm)
- C. 1" (25mm)
- D. 35" (889mm)
- E. 44" (1118mm)
- F. 40" (1016mm)

ST508a

**Fig. 17** Parallel installation, vertical chimney connector, two wall shields.

**Parallel installation with rear wall pass-through, two wall shields.** Fig. 18: Reduced clearances for both rear and side walls. Wall shields may meet at corner if desired. Shielding for connector is centered behind connector. Wall pass-through must comply with codes.

**Corner installation, vertical chimney connector, two wall shields.** Fig. 19: Reduced side clearances. Wall shields **MUST** meet at corner.

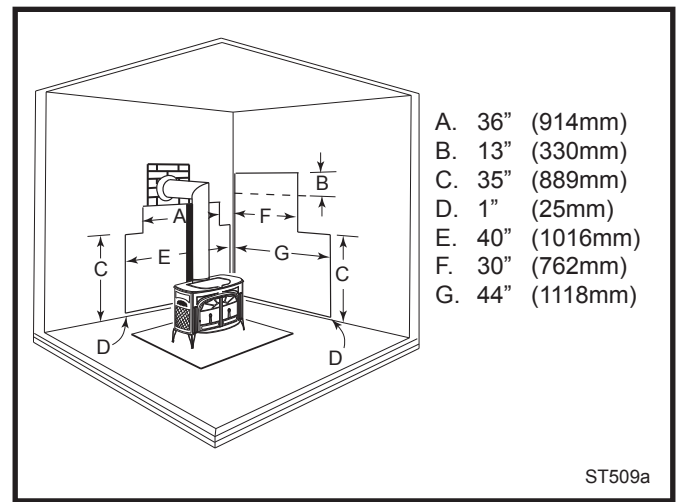

- A. 36" (914mm)
- B. 13" (330mm)
- C. 35" (889mm)
- D. 1" (25mm)
- E. 40" (1016mm)
- F. 30" (762mm)
- G. 44" (1118mm)

ST509a

**Fig. 18** Parallel installation with rear wall pass-through, two wall shields.

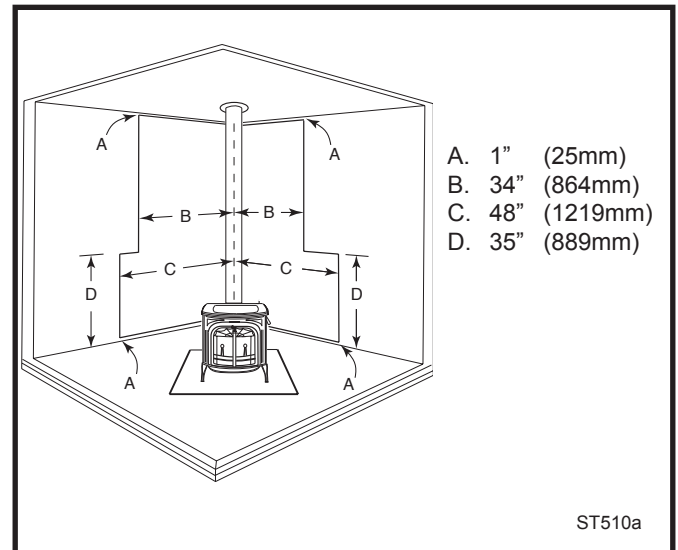

- A. 1" (25mm)
- B. 34" (864mm)
- C. 48" (1219mm)
- D. 35" (889mm)

ST510a

**Fig. 19** Corner installation, vertical chimney connector, two wall shields.

## Fireplace Clearances and Mantel Trim Shields

A fireplace installation requires special clearance between the side of the stove and the right and left walls, between the side of the stove and the decorative side trim on the fireplace face, and between the top of the stove and the mantel.

Noncombustible shields installed 1" (25mm) away from the combustible surface on noncombustible spacers, called ventilated shields, may be used to reduce clearances.

To protect a mantel from the heat of an Intrepid II in a fireplace installation, the ventilated mantel shield must be at least 48" (1219mm) long, and it must be centered over the stove. Ventilating shields for side trim must extend the full length of the trim.

An unprotected mantel ("A", Fig. 20.) cannot be more than 9" (229mm) deep and must have a minimum clearance of 30" (762mm), measured from the stove's top plate. With a ventilated shield, this clearance may be reduced safely to 14" (357mm).

Unprotected top trim (B) protruding 2" (51mm) or less from the face of the fireplace must be a minimum of 24" (610 mm) from the stove's top surface. With a ventilated trim shield, this clearance may be reduced safely to 14" (357mm).

Unprotected side trim (C) that protrudes 2" (51mm) or less from the face of a fireplace must have a minimum clearance of 15" (381mm), measured from the stove's top side edge. With a ventilated trim shield, the clearance may be reduced safely to 10" (254mm). If the trim extends more than 2" (51mm), wall clearance requirements apply.

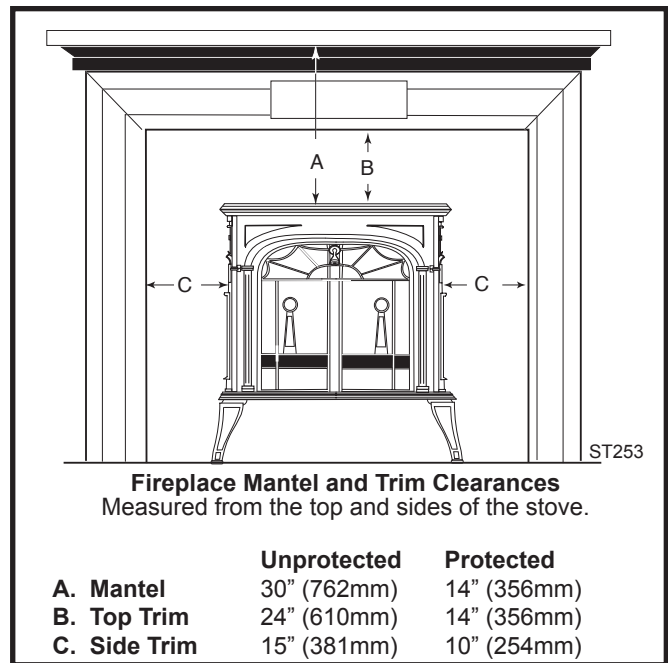

**Fig. 20** Maintain clearances to combustible components of the mantelpiece.

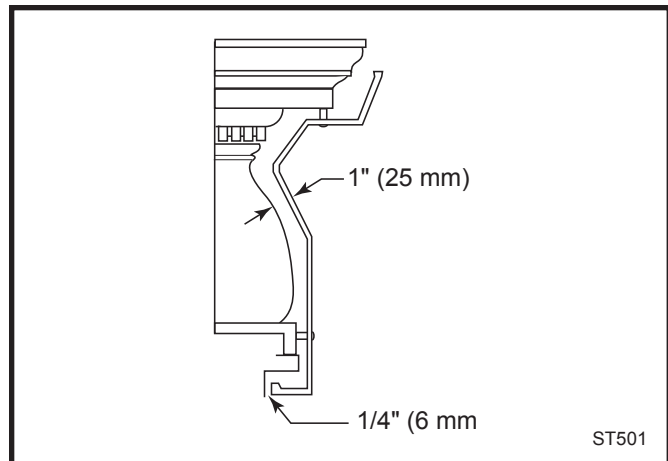

**Fig. 21** A custom-formed mantel shield.

## Alcove Installations

Because of their restricted air flow and heat retention characteristics, specific construction requirements and special clearances apply to installations into alcoves. No stove or chimney connector heat shields are used in alcove installations.

**ALCOVE INSTALLATION OF THE INTREPID II IS NOT PERMITTED IN CANADA.**

## Construction Requirements

The following illustrations show noncombustible ceiling framing and maximum and minimum permitted dimensions for alcove construction.

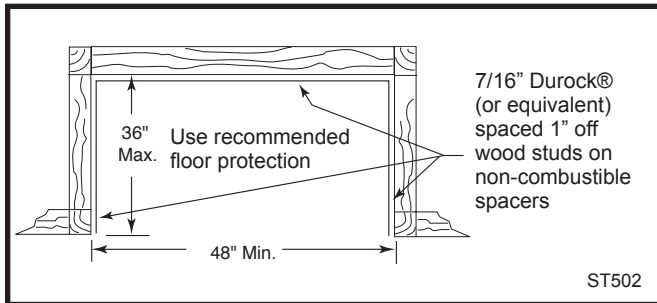

**Fig. 22** Alcove floor plan. Sheetrock on front face butts to Durock® (or equivalent) alcove lining.

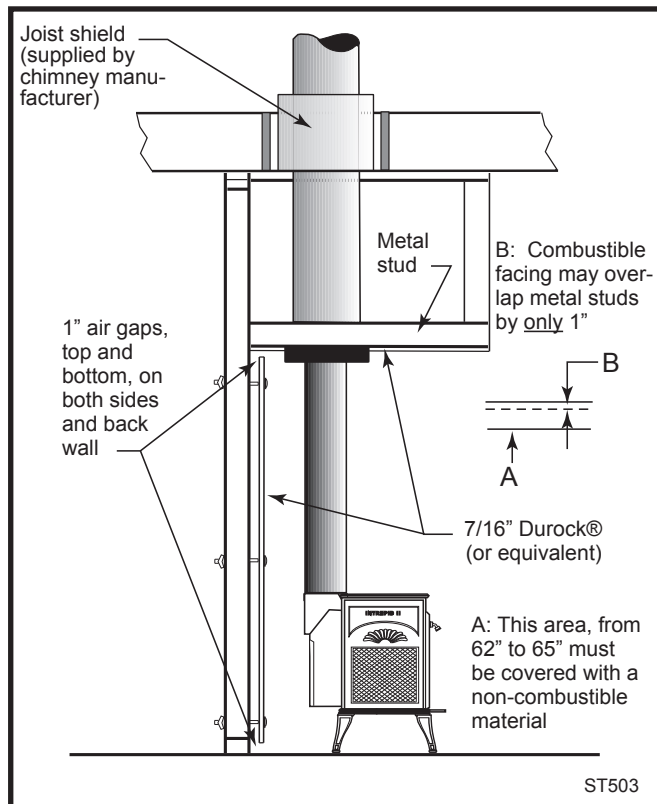

**Fig. 23** Alcove side section.

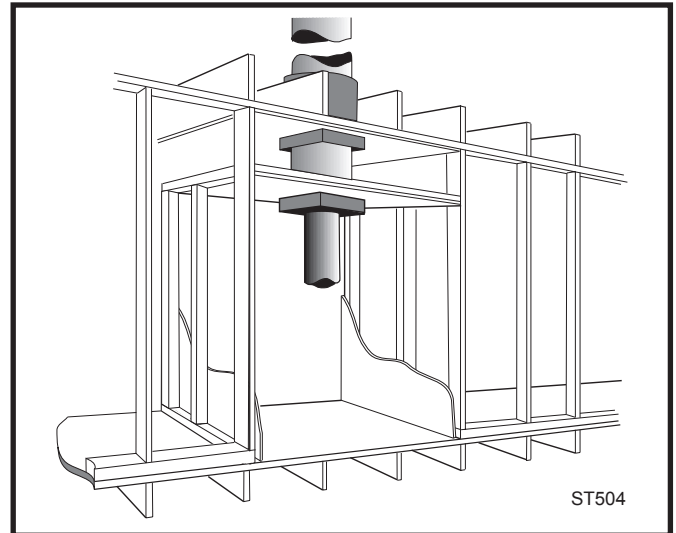

**Fig. 24** Cutaway perspective of alcove installation.

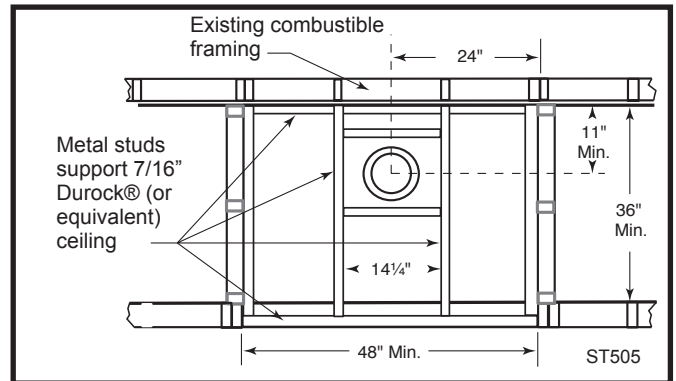

**Fig. 25** Reflected ceiling plan.

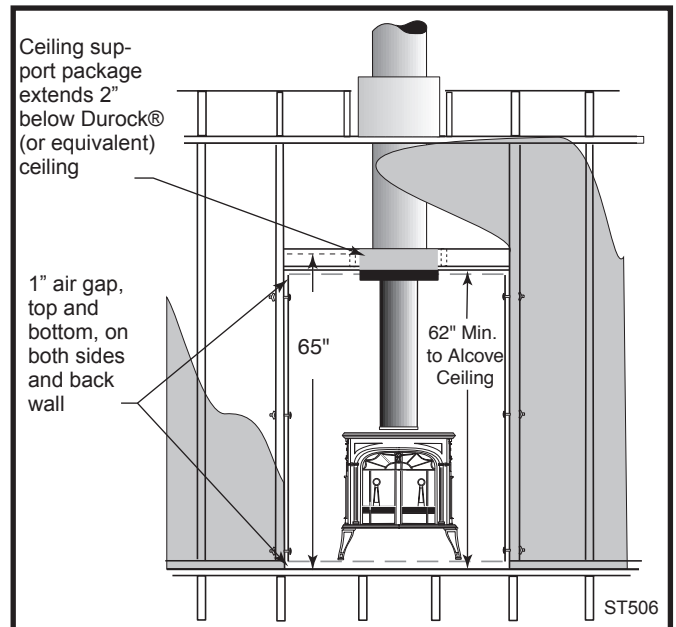

**Fig. 26** Front view: 65" minimum clearance from hearth to combustibles on front face. Combustible facing may overlap metal studs by only 1". It should not extend below the height of the non-combustible ceiling.

## Intrepid 1640 Clearance Chart

Use the chart below together with the diagrams on the next page to determine the required clearance for your particular installation.

Stove clearances are measured from the top plate to the combustible surface.

Chimney connector clearances are measured from the connector surface.

	Unprotected Surfaces			Protected Surfaces		
	<b>Stove Clearance</b>					
	Stove Installed Parallel to Wall		Stove in Corner	Stove Installed Parallel to Wall		Stove in Corner
	Side	Rear	Corners	Side	Rear	Corners
Top Exit, Single-wall Chimney Connector without Connector Shields	(A) 22" (559 mm)	(B) 26" (660 mm)	(C) 20" (508 mm)	(D) 12" (305 mm)	(E) 16" (406 mm)	(F) 10" (254 mm)
Top Exit, Single-wall Chimney Connector with Connector Heat Shields <sup>1, 2, 4</sup>	(G) 24" (610 mm)	(H) 16" (406 mm)	(I) 12" (305 mm)	(J) 12" (305 mm)	(K) 9" (229 mm)	(L) 10" (254 mm)
Rear Exit <sup>3</sup>	(M) 24" (610 mm)	(N) 14" (356 mm)	(NA)	(P) 12" (305 mm)	(Q) 9" (229 mm)	(NA)
Top Exit, Double-wall Chimney Connector <sup>5</sup>	(G) 24" (610 mm)	(H) 16" (406 mm)	(I) 12" (305 mm)		*	
	<b>Chimney Connector Clearance</b>					
Single-wall Chimney Connector, without Connector Heat Shields	26 " (660 mm)			12" (305 mm)		
Single-wall Chimney Connector, with Connector Heat Shields	10" (254 mm)			5" (127 mm) <sup>4</sup>		
Double-wall Connector <sup>5</sup>	12" (305 mm)			*		
	<b>Front Clearance to Combustibles</b>					
	48" (1219 mm)					

1. Shielding for a top exit stove must include the stove rear heat shield insert to protect the area behind the flue collar.
2. Chimney connector heat shields, in an installation that goes through a combustible ceiling, must extend to 1" (25mm) below the ceiling heat shield, which is 22" (559 mm) in diameter. The ceiling heat shield should be 24 gauge or heavier sheet metal, centered on the chimney connector, and mounted on non-combustible spacers.
3. Rear Exit—horizontal connection from flue collar directly back through wall.
4. The ceiling heat shield required when chimney connector shields are used should meet the wall protector. This will require trimming the ceiling shield along the line of intersection with the wall protector.
5. Requires the Flue Collar Shield Insert installed on the stove.

Unprotected Surfaces		Protected Surfaces	
Stove Installed Parallel to Wall	Stove in Corner	Stove Installed Parallel to Wall	Stove in Corner
<b>Top Exit No Chimney Connector Shields</b>			
<b>Top Exit with Chimney Connector Shields or Double-wall Chimney Connector</b>			
<b>Rear Exit</b>			
	N/A		N/A

ST507

## Assembly

You will need the following tools to assemble the Intrepid:

- 9/16" open end wrench
- safety glasses & gloves
- flat head screwdriver
- power drill w/ 1/8" (3mm) bit

**Caution. The Intrepid is very heavy. Do not attempt to handle the stove without assistance.**

### Unpack the Stove

1. Remove the shipping straps and plastic wrap.
2. Inspect the stove and contents for shipping damage or missing parts. Immediately notify your dealer of any damage. Do not install this stove if any damage is evident or any parts are missing.

#### Firebox Contents:

- Smokesheff Plate
- Upper Firebricks, 3
- Hardware Bag

#### Hardware Bag contents:

- Stove Legs, 4
- Hex Head Leg bolts with washers, 4
- #10 x 1/2" sheet metal screws, 3
- Door Handle Holder
- 5/32" Allen Wrench
- 1/8" Allen Wrench
- Furnace Cement, 3 oz. Tube
- Owner's Registration Card
- Touch-up Paint (Porcelain enamel stoves only)

3. Remove any wooden or cardboard packing material from the stove.

### Install Stove Legs

Remove and discard the four slot-head screws from the stove bottom. Have an assistant tilt the stove while you install first the back and then the front legs using the four 3/8-16 x 1" hex head bolts with 3/8" washers from the parts bag. The shoulder of the legs should seat within the locator tabs cast into the stove bottom at each corner. Tighten the bolts with the 9/16" wrench. **CAUTION: Overtightening can strip tapped threads.** Install the Door Handle Holder between the Right Front leg and the stove. (Fig. 27)

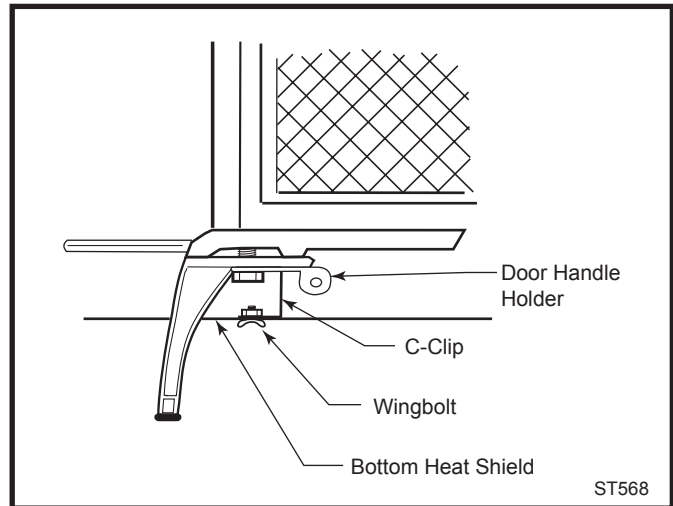

**Fig. 27** Install Legs and optional Bottom Heat Shield. The Handle Holder should be at the right front.

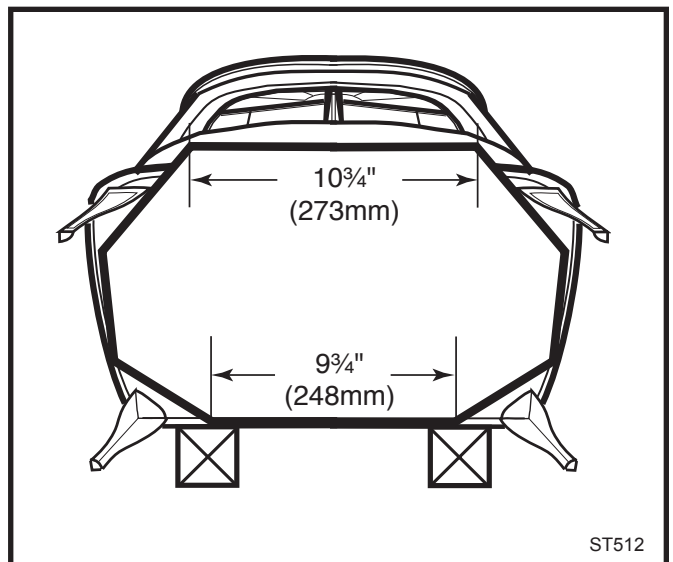

**Fig. 28** Bottom Heat Shield orientation.

### Install the Bottom Heat Shield

The optional # 0307 Bottom Heat Shield must be used in the U.S. and Canada in any installation on a floor that is not comprised of unpainted cement on earth.

1. Loosen each leg bolt enough to slip the shield C-Clips onto the bolt.
2. Orient the Bottom Heat Shield so that the longer edge is at the front. Refer to Figure 28. Attach the Bottom Heat Shield to the C-Clips using the wingbolts
3. Re-tighten the leg bolts

## Install Smokesheff / Firebricks

Look inside the firebox and locate the position for the Smokesheff. It will seat against the upper Back, directly under the Flue Collar. It is supported by ribs cast into the air manifolds on either side and along the back plate. (Fig. 29)

1. Orient the Smokesheff Plate as illustrated and apply a bead of furnace cement along the rib at the back edge.
2. Apply a bead of cement along the top of each Side Rib on which the Smokesheff will rest. (Fig. 29)
3. Position the Smokesheff above the #3 Air Tube so that it seats against the Back wall and upon the Side Ribs.
4. Insert the three Upper Firebricks into position above the Secondary Air Tubes as shown in Figure 30. Insert the bricks up between the #1 and #2 Air Tubes. The firebricks do not need cement - they simply rest directly upon the air tubes. Push each firebrick fully back against the Smokesheff plate.

## Flue Collar Reversal

The Intrepid is shipped with the Flue Collar in the Top Exit position. Follow these steps to orient the collar for a Rear Exit installation.

1. Remove the Flue Collar Heat Shield, (used for top-exit installations only).
2. Remove the two screws that attach the flue collar to the stove and turn the collar upside-down to face the rear.
3. Confirm that the gasket is seated properly and resecure the screws.

## Install the Outside Air Adaptor

The optional #1878 Outside Air Adaptor provides a collar to which a 3 inch diameter air duct may be attached directly to the air inlet area at the back of the stove.

Use the four sheet metal screws provided in the kit to attach the adaptor to the center mounting flange at the bottom of the Rear Shroud.

## Attach the Chimney Connector

1. Insert the crimped end of the first section of chimney connector into the flue collar.
2. Using the holes in the collar as guides, drill 1/8" (3mm) holes through the connector pipe.
3. Use the three #10 x 1/2" sheet metal screws provided to secure the chimney connection to the flue collar.

If applicable, attach Chimney Connector Heat Shields following the instructions included with those parts.

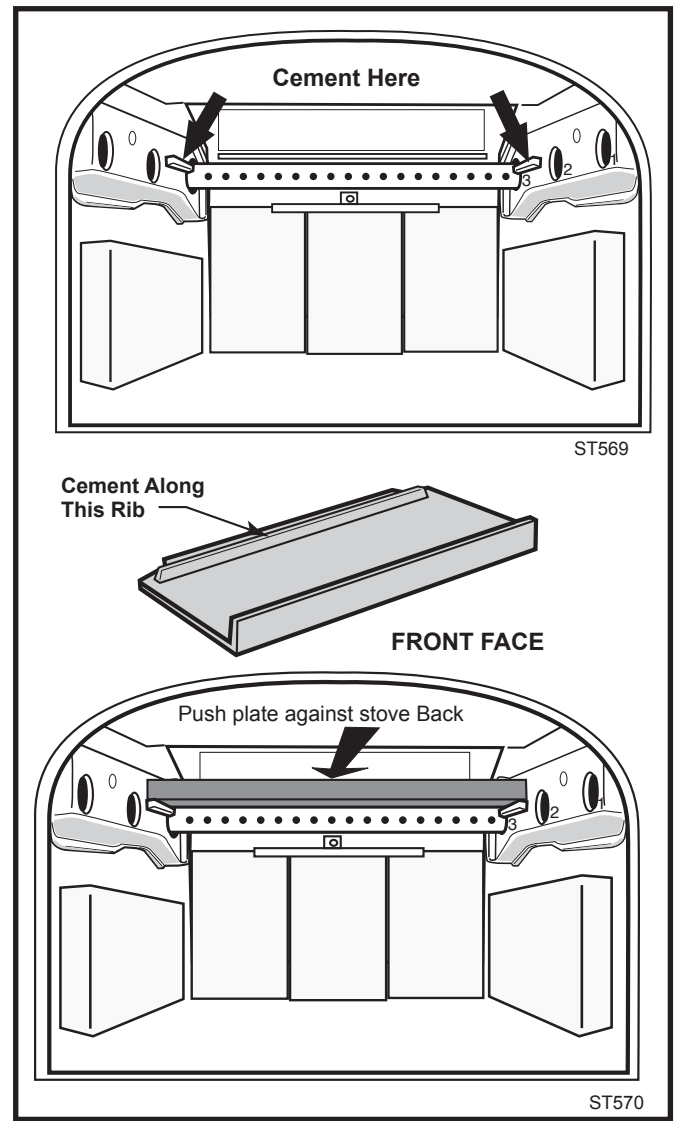

Fig. 29 Installing the Smokesheff.

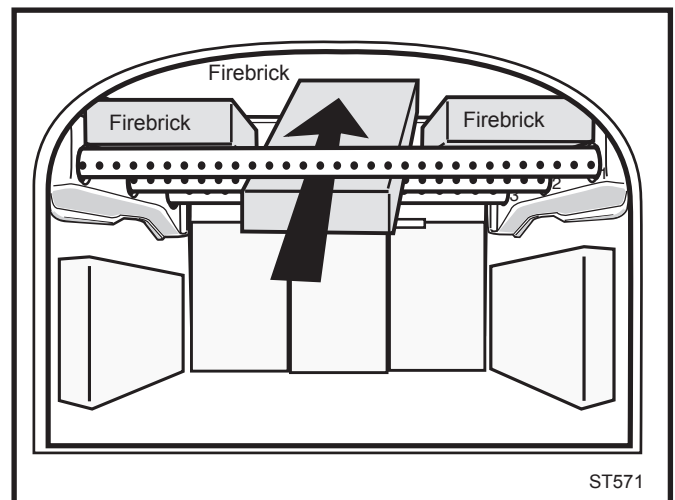

Fig. 30 Install the Upper Firebricks.

## Operation

### How the Intrepid Works

Combustion control is achieved in the Intrepid through two separate air delivery systems.

The **Primary Air Control Lever**, located at the left rear corner of the stove, controls the amount of incoming primary air for starting, maintaining, and reviving the fire. More air entering the stove makes the fire burn hotter and faster, while less air prolongs the burn at a lower heat level.

For the greatest air supply and maximum heat output (but the shortest burn time), place the lever all the way to the LEFT at the HIGH position. For a fire that will last longer with less heat, move the lever to the RIGHT toward the LOW position. You can set the lever anywhere in between the upper and lower extremes to moderate the fire intensity. (Fig. 27)

Another separate supply of oxygen is delivered to the upper area of the firebox to support combustion of gases released from the main fuel bed. This **Secondary Air** enters the stove through two, unrestricted inlets and is heated while passing through separate channels before being delivered through three stainless steel multi-ported tubes located at the top of the firebox.

### Burn Only High-Quality Wood

**The Intrepid is designed to burn natural wood only; do not burn any other fuels.**

**Do not use chemicals or fluids to start the fire. Do not burn garbage or flammable fluids such as gasoline, naphtha, or engine oil. Also, never use gasoline-type lantern fuel, kerosene, charcoal lighter fluid, or similar liquids to start or “freshen up” a fire. Keep all such liquids well away from the Intrepid while it is in use.**

**Caution: The Intrepid will be hot while in operation. Keep children, clothing and furniture away. Contact may cause skin burns.**

**Do not overfire this heater. Overfiring may cause a house fire, or can result in permanent damage to the stove. If any part of the stove glows, you are overfiring.**

You will enjoy the best results when burning wood that has been adequately air-dried. Avoid burning “green” wood that has not been properly seasoned. The wood should be no longer than 16” (410 mm) in length, however, you will find that shorter wood lengths ease refueling and promote the most efficient combustion.

The best hardwood fuels include oak, maple, beech, ash, and hickory that has been split, stacked, and air-dried outside under cover for at least one year.

For areas that do not have a supply of hardwood, commonly burned softwoods include tamarack, yellow pine, white pine, Eastern red cedar, fir, and redwood. These too should be properly dried.

Keep wood a safe distance from the heater and keep it out of the areas around the heater used for refueling and ash removal.

### Use the Air Control Setting that Works Best for You

No single air control setting will be appropriate for every situation. Settings will differ depending on the quality of the fuel, the amount of heat desired, and how long you wish the fire to burn.

The control setting also depends on your particular installation’s “draft,” or the force that moves air from the stove up through the chimney. Draft is affected by such things as the length, type, and location of the chimney, local geography, nearby obstructions, and other factors.

Too much draft may cause excessive temperatures in the Intrepid, and could even damage it. On the other hand, too little draft can cause backpuffing into the room and/or the “plugging” of the chimney.

How do you know if your draft is excessively high or low? Symptoms of too much draft include an uncontrollable burn or a glowing-red stove part. A sign of inadequate draft is smoke leaking into the room through the stove or chimney connector joints, low heat, and dirty glass.

In newer homes that are well-insulated and weather-tight, poor draft may result from insufficient air in the house. In such cases, a slightly opened window near the stove on the windward side of the house will provide the fresh air needed.

A more effective option for delivering ample combustion air to the stove is to duct air directly from outdoors to the stove. In fact, in some areas, provisions for outside combustion air are required in all new construction. The optional Intrepid Outside Air Adaptor is available from your dealer.

When you first begin using the stove, pay attention to the effects of different air control settings. You will quickly find that a specific setting will give you a fixed amount of heat. It may take some time to determine the amount of heat and the length of burn you should expect from various settings.

**Do not for any reason attempt to increase the firing of your heater by altering the air control adjustment range outlined in these directions.**

Before you start using the stove, please read the Appendix on Draft Management starting on Page 24 to learn how the characteristics of your installation will affect the stove's performance. You and the stove are parts of a system, and other parts of the system have a strong effect on operation; you may need to vary your firing technique to get the performance you want.

## Starting and Maintaining a Fire

### Conditioning Your Stove

Cast iron is extremely strong, but it can be broken with a sharp blow from a hammer or from the thermal shock of rapid and extreme temperature change. The cast plates expand and contract with changes in temperature. When you first begin using your Intrepid, minimize thermal stress by allowing the plates to adjust gradually during three or four initial break-in fires following **Steps 1-3**.

**Burn solid wood fuel only, and burn it directly on the grate. Do not elevate the fuel. Do not burn coal or other fuels.**

**WARNING: operate this stove only with the door fully closed.**

**The Primary Air Inlet must be open when starting a fire or when refueling.**

1. Open the primary air control fully by placing the Control Lever all the way to the LEFT (HIGH).
2. Place several sheets of crumpled newspaper in the stove. Avoid using glossy or colored paper, as these burn poorly. At the front of the firebox, place on the paper six or eight pieces of dry kindling split to a finger-width size, and on the kindling lay two or three larger sticks of split dry wood approximately 1-2" (25-50 mm) in diameter. (Fig. 28)

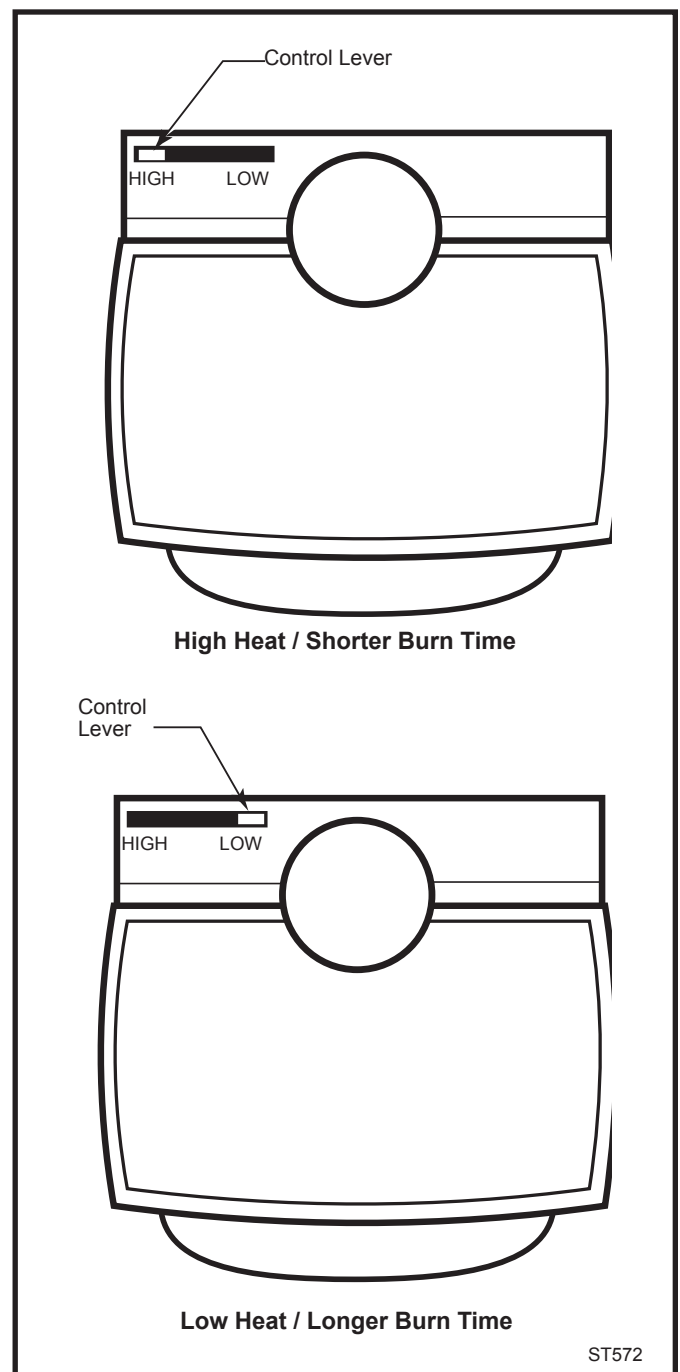

**Fig. 31** Primary Air Inlet Settings.

3. Light the newspaper and close the door. Gradually build up the fire by adding a few 3-5" (80-120 mm) diameter splits. (Fig. 29) If this is one of the first few "break-in" fires, let the fire burn brightly, and then let it die out.

- During the break-in fires, don't let the stove get hotter than 500°F. (260°C) as measured on an optional stove-top thermometer. Adjust the air control lever as necessary to control the fire.
- Some odor from the stove's hot metal, the paint, and the cement is normal for the first few fires.

**NOTE:** Some chimneys need to be "primed," or warmed up, before they will draw sufficiently to sustain a fire. Roll up a couple pieces of newspaper, place them on top of the kindling and toward the front of the stove, light them, and close the door. This should heat the chimney enough to initiate strong draft.

Once the draft is established, open the front door and light the rest of the fuel bed at the bottom. Do not light the main bed of fuel until the chimney begins drawing.

4. After the stove has been broken-in using Steps 1-3, continue to build the fire gradually. Add larger wood with a diameter of 3-4" (76-102mm).

Continue adding split logs of this size to the briskly-burning fire until there is a glowing ember bed at least 2" (51mm) deep. A good ember bed is necessary for proper functioning and may take up to an hour to establish.

5. Adjust the Air Control Lever to maintain the desired heat output.

### Refuel While the Embers Are Still Hot

**WARNING:** For safety and greatest efficiency, operate your stove only with all doors fully closed. The test standard for your stove when it is operated in this mode is UL 1482 for the United States and ULC S627 for Canada.

Your stove may be used as a fireplace with the front doors open or removed only when the spark screen is placed correctly in the opening to protect against the possibility of sparks and embers leaving your stove. The test standard for your stove when it is operated in this mode is UL 737 for the United States and CAN/CSA-B366.2 for Canada.

Use only the Intrepid Spark Screen, #0136 with your Intrepid. Intrepid Spark Screens are available from your Vermont Castings' Authorized Dealer.

Reload the Intrepid while it is still hot and there are plenty of glowing embers to re-ignite the fire. Include some smaller pieces of wood in the new load of fuel to help the stove return to its operating temperature quickly. Wear stove gloves, and follow this procedure when you reload your stove:

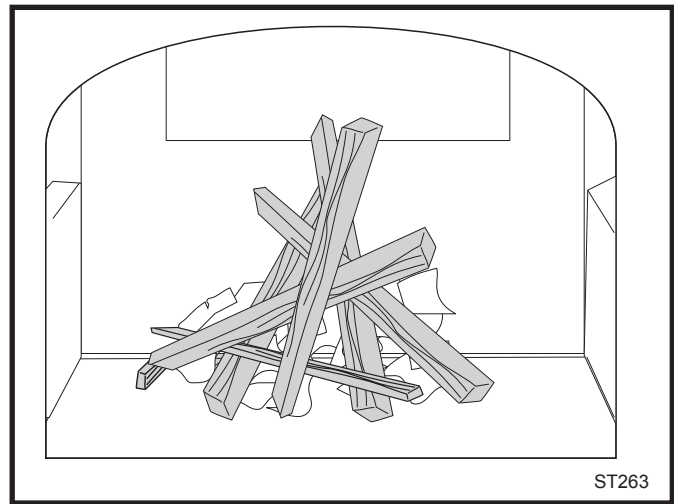

Fig. 32 Start a fire with small, dry kindling.

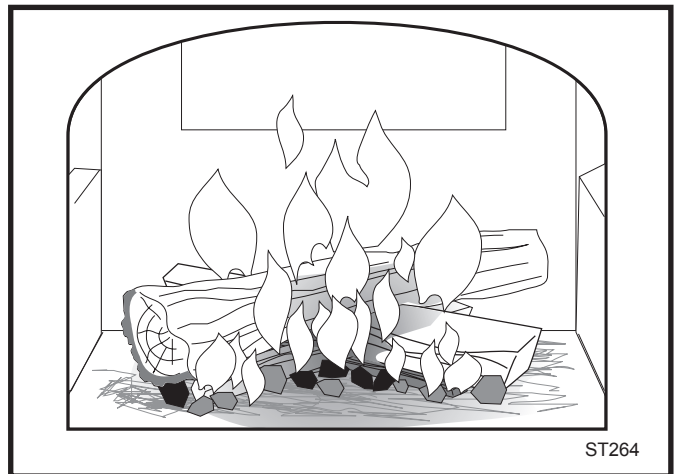

Fig. 33 Gradually add larger pieces of wood until all the wood is burning well.

1. Place the Air Control Lever to the fully open (HIGH) position
2. Open the door and check the ash level in the ash pan. If necessary, dispose of the ashes and replace the pan.
3. Use a fireplace tool to break up the charcoal and direct ash through the grate. Pull the charcoal from the back to the front. (Fig. 30) This will encourage efficient combustion as the fuel burns from front to rear.
4. Load wood — smaller, split pieces first. Close the door. Ideal performance will be achieved by operating with the air control set at HIGH for several minutes after refueling. Adjust the Air Control Lever for the desired heat output after the fire is re-established.

## Ash Disposal

Your Intrepid utilizes an ash grate to facilitate ash removal. You may wish to use an ash hoe to pull the accumulation forward from the firebricks to the grate where it will fall into the ashpan for easy removal.

Remove ash before it reaches the top of the ash pan. Check the level at least once a day, and before each re-fueling. Using stove gloves, pull the ash pan out of the stove by its handle. Remove the ash pan and properly dispose of the ashes. Be sure to keep the pan level during disposal.

Empty the ash pan regularly, typically every one to three days. The frequency will vary depending on how you operate your Intrepid; if you burn more wood at higher heat output settings, ash will accumulate rapidly.

Dispose of ashes into a metal container with a tight-fitting lid kept outdoors. Put the closed container of ash on a noncombustible floor or on the ground, well away from all combustible materials, pending final disposal. If the ash is disposed of by burial in soil or otherwise locally dispersed, keep it in the closed container until all cinders have thoroughly cooled. You can use wood ash as a garden fertilizer.

**CAUTION: Never use your household or shop vacuum cleaner to remove ash from the stove; always remove and dispose of the ash properly.**

**CAUTION: Avoid slamming the stove door or striking the glass panel. Do not operate the stove with the glass panel missing, damaged, or broken. Do not install substitute materials. See Maintenance section for replacement instructions.**

## Smoke Detectors

The use of smoke detectors throughout the home is strongly advised, if not required by building codes or insurance regulations. It is a good idea to install a smoke detector in the living areas and each bedroom.

You may not, however, wish to install a detector in the immediate vicinity of the stove. Depending on the sensitivity of the unit, the alarm can be set off while you are tending the fire or emptying the ashes. If you install a detector in the same room, locate it as far away from the stove as possible.

## Maintenance

Let the fire in the stove go out and allow the stove to cool completely before beginning any maintenance procedure.

### Care of the Cast Iron Surface

An occasional dusting with a dry rag will keep the painted cast iron of your Intrepid looking new.

The stove's paint can be touched up as needed. First, clean the areas to be painted with a wire brush. Then, touch up the stove with Vermont Castings high temperature stove paint. Apply the paint sparingly, and keep in mind that two light coats of paint are better than a single heavy one.

### Care of Porcelain Enamel Finish

Use a dry or slightly damp rag or a soft brush to remove spills or stains. For difficult jobs that require a cleaning agent, use only a kitchen appliance cleaner or polish recommended for use on enamel surfaces.

### Cleaning the Glass

Most of the carbon deposits on the glass will burn off during hot fires. However, the ash residue that accumulates on the glass surface should be removed regularly to prevent etching. Follow this procedure to clean the glass:

- Be sure the glass is completely cool.
- Clean the glass with water or a cleaner made especially for this purpose. Do not use abrasive cleaners.
- Rinse the glass thoroughly.
- Dry the glass completely.

### Glass Replacement

Replace glass only with Vermont Castings part no. 1401156 Right Side and 1401157 Left Side Glass Panels. The glass panel rests on a cushion provided by 3/16" rope gasket, #1203556 and is held in place by clips. (Fig. 35) The glass is IR coated on one side which is marked **THIS SIDE OUT**.

1. Remove the door from the stove and place it on a sturdy, level work surface. Use a towel to protect the porcelain enamel finish.
2. Remove phillips head screws and retainer clips.
3. Inspect the Gasket. If the window gasket is in good condition, you can leave it in place. If you replace it, use only #1203556. Be sure the channel around the window opening is clean, and free of dust.

4. Install the Glass. Lay the glass on the inner gasket with the coated side down (toward the outside of the door). Tighten the screws snugly, but loose enough to allow for a little movement of the glass when the stove is in operation. Overtightening can crack the glass immediately or cause it to crack if it is unable to expand when hot.

### Gasket Replacement

Your Intrepid uses 5/16" dia. rope-type fiberglass gaskets to make a tight seal at the Front Doors and the Flue Collar. With use, particularly on those parts that move, gaskets can become brittle and compressed and may require replacement.

Wait until the fire is out and the stove has cooled. Be sure to follow the standard safety procedure for working with dusty materials: Wear safety goggles and a dust mask.

1. Remove the existing gasket by grasping an end and pulling firmly.
2. Use a wire brush or a screwdriver to clean the channel of any remaining cement or bits of gasket. Remove stubborn deposits of cement with a cold chisel if necessary.
3. Determine the correct length of the appropriate-sized gasket by laying it out in the channel. Allow an extra 1-2" (25-50 mm), and mark the spot to be cut.

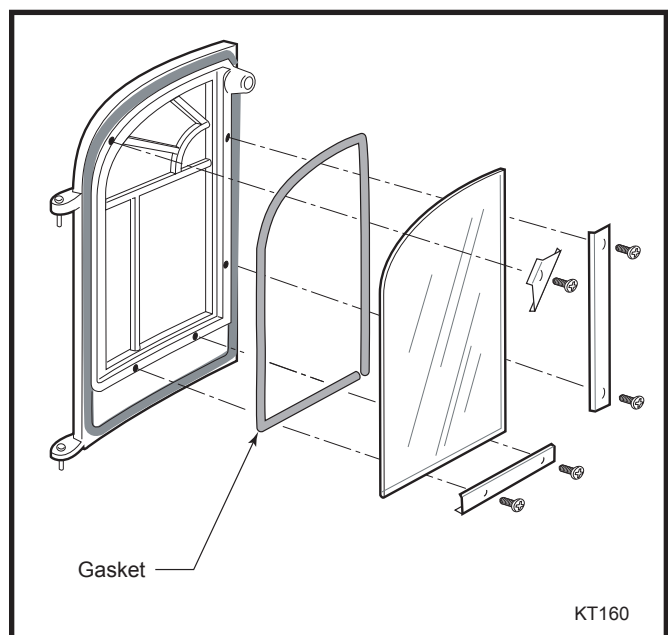

Fig. 35 Door glass installation.

4. Remove the gasket from the channel, place it on a wood cutting surface, and cut it at the marked spot with a utility knife. Twist the ends slightly to discourage the gasket from unraveling.
5. Lay an unbroken 1/8" (3 mm) bead of gasket cement in the newly-cleaned channel.
6. Starting at one end, press the gasket into the channel. Ensure a good joint where the gasket meets before trimming any excess. Do not overlap the gasket ends or leave ends with ragged edges.
7. Press the gasketed part firmly against its normal mating surface to seat the gasket evenly in its channel. Close and latch the door to do this; close the door on a piece of waxed paper to keep the cement from migrating onto the non-gasketed part, or tap other parts
8. Clean excess cement from around the channel. Let the cement that holds the new gasket dry thoroughly.

### Adjust the Door Latch

Over time, the door latch mechanism may need adjustment to compensate for compression of the door gasketing.

1. Using the 5/32" Allen wrench supplied with the stove, loosen the Small Locknut enough to extend the Striker Screw one turn clockwise into the Pawl.
2. Retighten the Small Locknut while keeping the Striker Screw from turning. Test the door latch closure. You should feel some resistance as you turn the handle down through the fully closed position. Make small adjustments as necessary to achieve a secure latch.

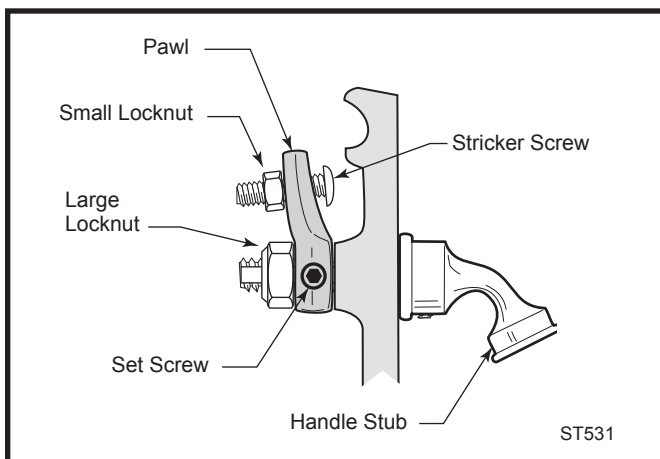

Fig. 36 Door Latch Adjustment

## The Chimney System

### Creosote

Your Intrepid is designed to reduce creosote buildup significantly. However, regular chimney inspection and maintenance must still be performed. For safety, good stove performance, and to protect your chimney and chimney connector, inspect your chimney and chimney connector on a regular schedule. Clean the system if necessary. Failure to keep the chimney and connector system clean can result in a serious chimney fire.

**When wood is burned slowly, it produces tar, organic vapors and moisture that combine to form creosote. The creosote vapors condense in the relatively cool chimney flue. As a result, creosote residue accumulates on the flue lining. When ignited, this creosote makes an extremely hot fire within the flue system that can damage the chimney and overheat adjacent combustible material.**

If you do have a chimney fire, promptly:

- **Shut off the air supply by placing the Air Control lever all the way to the left (LOW).**
- **Get everyone out of the house.**
- **Call the Fire Department.**

You should inspect the system every two weeks during the heating season as part of a regular maintenance schedule. To inspect the chimney, let the stove cool completely. Then, using a mirror and a strong light, sight up through the flue collar into the chimney flue. If it is not possible to inspect the flue system in this fashion, the stove must be disconnected to provide better viewing access.

If a significant layer of creosote has accumulated — 1/8" (3 mm) or more — remove it to reduce the risk of a chimney fire.

Clean the chimney using a brush the same size and shape as the flue liner. Flexible fiberglass rods are used to run the brush up and down the liner, causing any deposits to fall to the bottom of the chimney where they can be removed through the clean-out door.

The chimney connector should be cleaned by disconnecting the sections, taking them outside, and removing any deposits with a stiff wire brush. Reinstall the connector sections after cleaning, being sure to secure the individual sections with sheet metal screws.

If you cannot inspect or clean the chimney yourself, contact your local Vermont Castings' Authorized Dealer or hire a professional chimney sweep.

## **Annual Maintenance**

Perform a thorough cleaning, inspection and repair each Spring, at the end of the heating season.

- Thoroughly clean the chimney and chimney connector.
- Inspect the chimney for damage and deterioration. Replace weak sections of prefabricated chimney. Have a mason make repairs to a masonry chimney.
- Inspect the chimney connector and replace any damaged sections.
- Check gasketing for wear or compression, and replace if necessary. A 'paper test' will guide you on this. Close and lock the door or damper on a slip of paper and then try to pull the paper out. If the paper pulls out with little or no resistance, the gasket isn't snug enough at that spot. If adjusting the damper or latch doesn't result in a seal that makes it hard to pull the paper out, replace the gasketing.
- Check door handle for tightness. Adjust if needed.
- Check heat shield screws. Tighten as necessary.
- Clean dust from the inner sides of bottom, rear and connector heat shields.
- Remove ashes from the ash pan and replace with moisture absorbing material (such as cat litter) to keep the stove interior dry. Close the stove door to keep cats from using the litter.
- Touch up the paint on black stoves.

## Draft Management

Your stove is only one part of a system that includes the chimney, the operator, the fuel and the home. The other parts of the system will affect how well the stove works. When there is a good match between all the parts, the stove works well.

Wood stove operation depends on natural (unforced) draft. Natural draft occurs when exhaust gas is hotter (and therefore lighter) than the outdoor air at the top of the chimney. The greater the temperature difference, the stronger the draft. As the hot exhaust gas rises out of the chimney it generates suction that draws air into the stove for combustion. A slow, lazy fire with the stove's air inlets fully open indicates a weak draft. A brisk fire, supported only by air entering the stove through the normal inlets, indicates a good draft. The inlets are passive; they regulate how much air can enter the stove, but they do not move air into it.

The efficiency of a modern woodburning appliance, (in which the amount of air available for combustion is regulated), depends on the chimney to keep exhaust gases warm all the way outdoors. The characteristics of your chimney - whether it is steel or masonry, interior or exterior, matched or mismatched to the stove collar - determine how quickly it will warm up and how well it will sustain the optimum temperatures necessary to maintain strong draft and efficient combustion. Here follows a description of various flue system characteristics and related effects on stove performance.

### Masonry Chimney

Although masonry is the traditional material used for chimney construction, it can have distinct performance disadvantages when used to vent a controlled-combustion woodstove. Masonry forms an effective 'heat sink' - that is, it absorbs and holds heat for long periods of time. The large mass, however, may take a long time to become hot enough to sustain a strong draft. The larger the chimney (in total mass), the longer it will take to warm up. Cold masonry will actually cool exhaust gases enough to diminish draft strength. This problem is compounded if the chimney is located outside the home or if the chimney flue has a cross-sectional size larger than the stove outlet.

### Steel Chimney

Most factory-made 'Class A' steel chimneys have a layer of insulation around the inner flue. This insulation keeps the smoke warm and protects the surrounding structure from the high flue temperatures. Because the insulation is less dense than masonry, the inner steel liner warms up more quickly than a masonry chimney. Although steel chimneys are not as attractive as their

masonry counterparts, they are very durable and generally outperform masonry.

### Inside/Outside Location

Because the chimney's function is to keep the smoke warm, it is best to locate it inside the house. This location uses the house as insulation for the flue and allows some radiant heat release from the flue into the home. Since an interior chimney does not continuously lose its heat to the outdoors, it takes less heat from the stove to get it warm and keep it warm.

### Flue Sizing

The flue size for a controlled-combustion appliance should be based on the cross-sectional volume of the stove flue outlet. In this case, more is definitely not better. Hot gases lose heat through expansion; if a stove with a six-inch flue collar (28 square inch area) is vented into a 10" x 10" flue, the gases will expand to over three times their original volume. As gases cool with expansion, draft strength decreases. If an oversized flue is also outside the house, the heat it absorbs will be conducted to the outdoor air and the flue will remain relatively cool.

It is common for a masonry flue to be oversized for the stove. Such a chimney can take quite a while to warm up and the stove performance will likely be disappointing. The best solution to an oversize flue problem is the installation of an insulated steel chimney liner of the same diameter as the appliance flue outlet. The liner keeps the exhaust gas warm and the result is a stronger draft. An uninsulated liner is a second choice - although the liner will keep the exhaust restricted to its original volume, the air around the liner will require time and heat energy to warm up.

Check your local codes. You may be required to install a flue liner in any oversize or masonry flue.

### Pipe & Chimney Layout

Every bend in the flue will act as a brake on the exhaust as it flows from the firebox to the chimney cap. The ideal pipe and chimney layout is straight up from the stove through a completely straight chimney. Use this layout if at all possible as it will promote optimum stove performance and simplify maintenance.

If the stovepipe must elbow to enter a chimney, locate the elbow about midway between the stove top and the chimney thimble. This configuration lets the smoke speed up before it must turn, keeps some pipe in the room for heat transfer, and allows long-term flexibility for installing a different appliance without relocating the thimble.

There should be no more than eight feet of single-wall stove pipe between the stove and a chimney. Longer runs can cool the smoke enough to cause draft and creosote problems. Use double-wall stove pipe for longer runs.

### Single Venting

Your stove requires a dedicated flue. Do not connect the stove to a flue used by any other appliance. Chimney draft is a natural form of energy and follows the path of least resistance. If the stove is vented to a flue that also serves an open fireplace or another appliance, the draft will also pull air in through those avenues. The additional air flow will lower flue temperatures, reduce draft strength and promote creosote development; overall stove performance will suffer. The effect is similar to that of a vacuum cleaner with a hole in the hose. In some extreme instances, the other appliance can even impose a negative draft and result in a dangerous draft reversal.

### Fuel

Even the best stove installation will not perform well if poor fuel is used. If available, always use hardwood that has been air-dried ('seasoned') 12-18 months. Softwood burns more rapidly than hardwood and has a high resin content conducive to creosote production. Decayed wood of any type has little heat value and should not be used.

All unseasoned ('green') wood has a high moisture content. Much of its heat value will be used to evaporate moisture before the wood can burn. This significantly reduces not only the amount of energy available to warm your home, but also the intensity of the fire and temperature of the exhaust gas. Incomplete combustion and cool flue temperatures promote creosote formation and weak draft.

You can judge the moisture content of wood by its appearance and weight or use a commercially available moisture meter for an exact measurement. Unseasoned wood will be a third heavier than dry wood. Also, look for cracks ('checking') in the ends of the log that result from contraction as the wood dries. The longer and wider the cracks, the dryer the wood is.

Purchase your fuel from a reputable dealer.

### Creosote

Creosote is a by-product of low-temperature stove operations, weak draft or both. It is a tar that results when unburned gases condense inside the flue system at temperatures below 290°F. Creosote is volatile and can generate chimney fire. All of the installation characteristics that adversely affect chimney draft also promote creosote condensation. Consequently, you can minimize creosote accumulation with an effective chimney design and the use of operational techniques that encourage good draft and complete combustion.

### Backpuffing

Backpuffing is a condition that results when the draft is too weak to pull flue gases out of the chimney system as fast as the fire is generating more. Volatile gases build up within the firebox until reaching a density and temperature at which they ignite. With this ignition, you may hear a muffled popping sound and see a bit of smoke forced out of the air inlets.

This condition is most likely to occur in the spring or fall when moderate outdoor temperatures and low intensity fires combine to inhibit draft strength. If your stove backpuffs, open the damper to let the smoke rise to the flue more quickly. Also, open the air inlets to induce a livelier fire and speed airflow through the stove. Avoid large loads of firewood at one time. You should always see lively, dancing flames in the firebox; a lazy, smoky fire is inefficient and will promote draft problems.

### Draft Testing

An easy way to determine whether your chimney draft is strong enough is to close the stove damper, wait a few minutes to let the airflow stabilize, and then test whether you can vary the strength of the fire by swinging the air control open and closed. Results here are not always instant; you may need to wait a few minutes for a change in the air control setting to have an effect on the fire. If there is no change, the draft is not yet strong enough to let you close the damper. You will need to open it for awhile longer and manage the fire with the air inlet until the draft strengthens. Keep a record of your operational habits and relate them to their effects on the stove's function. You will be rewarded with safe and efficient performance.

## **Negative Pressure**

Good draft also depends on a sufficient supply of air to the stove. The chimney cannot pull more air than is available. Sluggish draft can be caused by a house that is tight enough to prevent the ready flow of air to the stove, or by competition between the stove and other appliances that vent indoor air to the outside; i.e., exhaust fans for range hoods, clothes dryers, bathroom, etc. If the chimney draws well when all such equipment is turned off (or sealed, in the case of the fireplaces and/or other stoves), you simply need to be attentive in timing the use of the other appliances. If you need to crack a nearby window or door to enable the chimney to pull well, you should install an outside-air intake to bring combustion air directly to the stove. Consult your Vermont Castings dealer regarding an adapter to attach to the stove to connect an air duct for outdoor combustion air.

## **Conclusion**

Woodburning is more an art than a science. Art includes technique and since installations, homes and fuel vary, the stove operator must also vary technique, (mostly timing), to achieve satisfying results. Over time, you will become familiar with the intricacies and nuances of your particular installation and you will be able to identify cause and effect in a variety of seasonal circumstances.

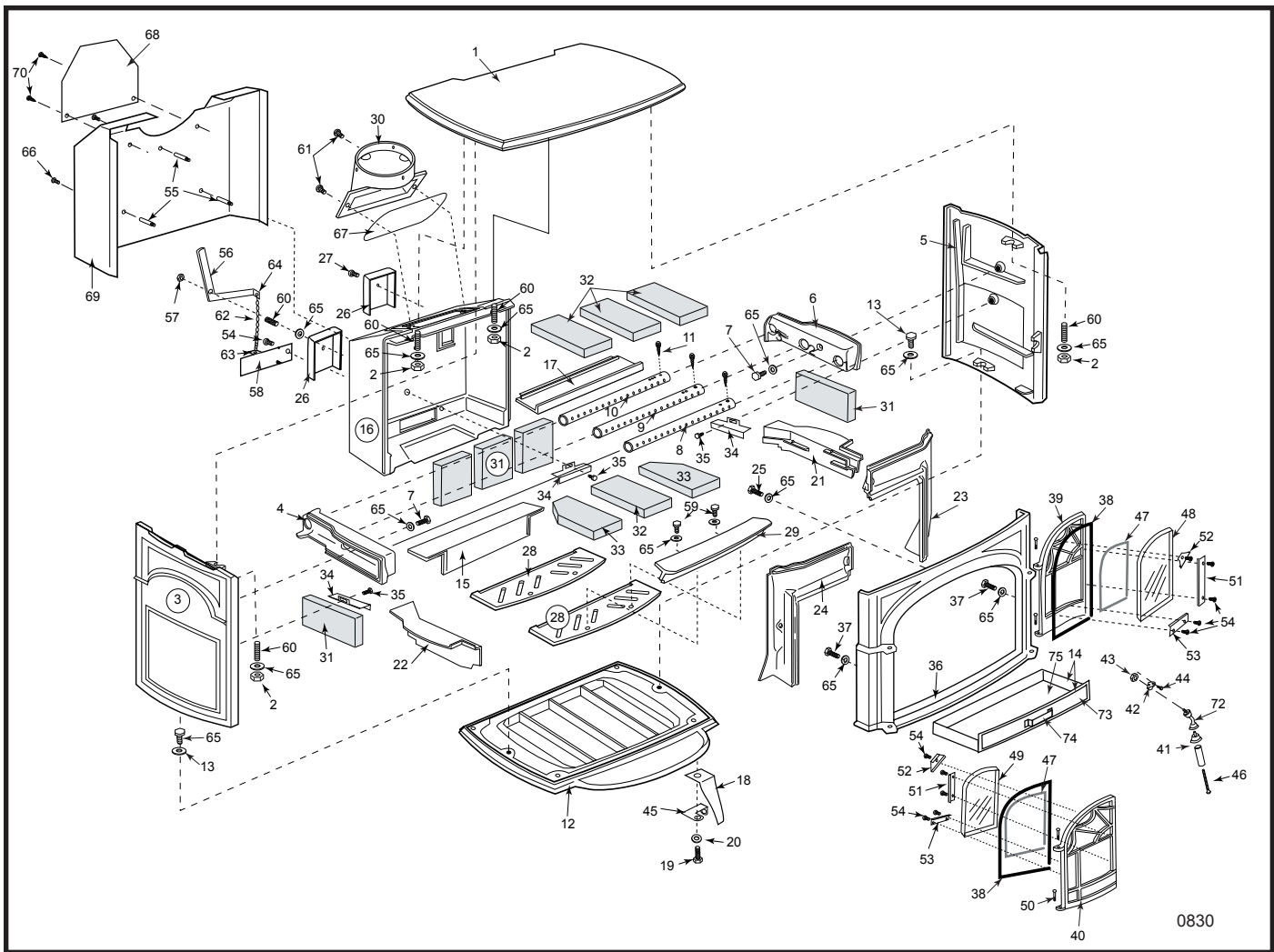

CFM Specialty Home Products reserves the right to make changes in design, materials, specifications, prices and discontinue colors and products at any time, without notice.

# Intrepid NC Woodburning Stove

## Model 1640

Item Description	Part Number
1. Top	See Chart Pg. 29
2. Hex Nut, 1/4-20 (5)	1203210
3. Right Side	See Chart Pg. 29
4. Secondary Air Manifold, Right	30000819
5. Left Side	See Chart Pg. 29
6. Secondary Air Manifold, Left	30000820
7. 1/4-20 x 2 1/4, CS Hex Hd Screw (2)	1201403
8. Secondary Air Tube, #A	30000825
9. Secondary Air Tube, #B	30000898
10. Secondary Air Tube, #C	30000805
11. #6-5/8 CS Socket Hd, SS Screw (3)	30000975
12. Bottom	See Chart Pg. 29
13. 1/4-20x1" CS Hex Hd, Blk Screw (2)	1201376
14. Ashpan Assembly	30000966
15. Shelf, Bottom	30000823

Item Description	Part Number
16. Back	30000821
17. Smokeshaft	30000822
18. Leg (Single)	See Chart Pg. 29
19. Leg Bolt, 3/8"-16x1" hex Bolt (4)	1201432
20. 3/8" Flat Washer (4)	1202488
21. Primary Air Manifold, Right	30000836
22. Primary Air Manifold, Left	30000837
23. Front Air Manifold, Right	30000838
24. Front Air Manifold, Left	30000839
25. 1/4-20x3/4" CS Hex Hd, Blk Screw	1201374
26. Secondary Air Cover (2)	30000869
27. 1/4-20 x 3/4", Blk Flat Hd Phillips Screw	1200881
28. Grate, Ash (2)	30000856
29. Grate, Lip	30000807
30. Flue Collar	See Chart Pg. 29

# Intrepid NC Woodburning Stove

## Model 1640 (continued)

Item Description	Part Number
31. Firebrick, Sides and Back (5)	30000969
32. Firebrick, Upper (3) and Mid. Bottom (1)	1601103
33. Firebrick, Bottom - Left & Right (2)	30000971
34. Brick Bracket (3)	30000986
35. 1/4-20 x 1/4" Phillips Flt Hd Screw Blk (3)	1200897
36. Front	See Chart Pg. 29
37. 1/4-20x1" Flat Hd Philips, Blk Screw (2)	1200815
38. 5/16" Fiberglass Gasket, Doors (5 ft.)	1203588
39. Right Door	See Chart Pg. 29
40. Left Door	See Chart Pg. 29
41. Ceramic Handle Assembly	0004342
42. Door Pawl Assembly	5004025
43. Nut, Hex Jam, 3/8-16	1203290
44. 1/4-20x3/4" Rnd Hd Phillip Screw Blk	1200461
45. Handle Holder	1600600
46. Handle Bolt, 1/4-20x 3/8"	1201294
47. Gasket, Fiberglas 3/16" 4nd, Blk	1203556
48. Glass Panel, Right <sup>2</sup>	1401156
49. Glass Panel, Left <sup>2</sup>	1401157
50. Hinge Pin, Door (4)	1600535
51. Side Glass Clip (2)	30000833
52. Corner Glass Clips (2)	30000834
53. Bottom Glass Clips (2)	30000832

Item Description	Part Number
54. Truss Hd, PH 10-24 x 1/2-Z (10)	1200998
55. Spacer, HS 1/4" (3)	1601755
56. Primary Air Rod	30000892
57. Hex Nut, 1/4-20 Flex Lock	1203213
58. Primary Air Flap	30000827
59. 1/4-20x5/8" Black Hex Screw (2)	1201372
60. Rod, Threaded Ends (5)	1204214
61. 1/4-20x3/4" Rnd Hd Phillip Screw Ni (2)	1200901
62. Ball Chain, #6	1201960
63. Jump Ring	1201985
64. Ball Chain Fitting	1201972
65. 1/4 Flat Washer, 7/8" O.D. (13)	1202470
66. 10-24x3/8" Rnd Hd Sltd Screw, Black (6)	1200985
67. Gasket- Flue Collar , 5/16" Self-adhesive	1203591
68. Flue Collar Heat Shield	30000863
69. Rear Convection Shroud	30000826
70. #10 x 1/2" Blk Phillips Sheetmetal Screw (2)	1202058
72. Faucet Stub Chrome w/Shaft	5004245
73. Ashpan Front	1306493
74. Ashpan Handle	30000973
75. Ashpan Only	30000966
76. Pan Hd, P 10-24 x 3/8-Z (1)	1200983

Shell Enamel Parts - Intrepid NC Model 1640							
Part Name	Classic	Green	Moonlight	Sand	Red	Blue	Suede Brown
Top	30000824	30000955	30001411	30000945	30000940	30000950	30002507
Bottom	30000855	30000959	30001407	30000949	30000944	30000954	30002501
Left Side	30000854	30000958	30001409	30000948	30000943	30000953	30002503
Right Side	30000853	30000957	30001408	30000947	30000942	30000952	30002502
Flue Collar	1306561	2316561	2376561	1326561	2326561	1336561	30002508
Front	30000852	30000956	30001410	30000946	30000641	30000951	30002504
Left Door	1308649	2318649	2378649	1328648	2328649	1338649	30002506
Right Door	1308648	2318648	2378648	1328648	2328648	1338648	30002505
Single Leg	1306333	2316333	2376333	1326333	2326333	1336333	30002509

**Notes:**

1. In this diagram and throughout this manual, 'left' and 'right' mean as you face the stove.
2. Use only Vermont Castings Glass Panels for replacement.
3. Part numbers for cast iron parts in this diagram are for 'Classic' (Black painted) stoves. When ordering enamelled parts, be sure to specify color.
4. Hardware in this stove is in standard U.S. (inch) sizes. Most fastener items are available at local hardware stores.

Maintenance Kits available from your dealer:

- #1884 Gasket Kit
- #3427 Glass Door Gasket Kit

To learn the name of the dealer nearest you, call or write:

CFM Specialty Home Products  
 475 Admiral Blvd.  
 Mississauga, Ontario L5T 2N1  
 800 525-1898



# Warranty

## Limited 3 Year Warranty

CFM Specialty Home Products warrants that this woodburning stove will be free of defects in material and workmanship for a period of three years from the date you receive it, except that the catalyst, thermostat assembly, handles, glass door panels, cement, and gasketing shall be warranted as described below.

CFM Specialty Home Products will repair or replace, at its option, any part found to be defective upon inspection by a Vermont Castings, Authorized Dealer. The customer must return the defective part or the stove, with shipping prepaid, to the Authorized Dealer or pay for any Authorized Dealer in-home travel fees or service charges for in-home repair work. It is the dealer's option whether the repair work will be done in the customer's home or in the dealer's shop. If, upon inspection, the damage is found to be the fault of the manufacturer, repairs will be authorized at no charge to the customer for parts and/or labor.

Any woodburning stove or part thereof that is repaired or replaced during the limited warranty period will be warranted under the terms of the limited warranty for a period not to exceed the remaining term of the original limited warranty or six (6) months, whichever is longer.

## Limited 1 Year Warranty

The following parts of the woodburning stove are warranted to be free of defects in material and workmanship for a period of one year from the date you receive it: The thermostat assembly, handles, glass door panels, cement, and gasketing. Any of these items found to be defective will be repaired or replaced at no charge, upon the return of the part with postage prepaid to a Vermont Castings Authorized Dealer.

Any part repaired or replaced during the limited warranty period will be warranted under the terms of the limited warranty for a period not to exceed the remaining term of the original limited warranty or six (6) months, whichever is longer.

## Limited Catalyst Warranty

The catalyst will be warranted for a six year period as follows: If the original catalyst or a replacement catalyst proves defective or ceases to maintain 70% of its particulate emission reduction activity (as measured by an approved testing procedure) within 24 months from the date the stove is received, the catalyst itself will be replaced free.

From 25 - 72 months a pro-rated credit will be allowed against a replacement catalyst and the cost of labor necessary for its installation at the time of replacement.

For stove purchases made after June 30, 1990, a third year (25 - 36 months) of no charge replacement will be made when combustor failure is due to thermal degradation of the substrate (crumbling of ceramic material). The customer must pay for any in-home travel fees, service charges, or transportation costs for returning the stove to the Authorized Dealer.

Amount of Time Since Purchase	Credit Towards Replacement Cost
0 - 24 months	100%
25 - 36 months	50 %
37 - 48 months	30%
49 - 60 months	20%
61 - 72 months	10%

Any replacement catalyst will be warranted under the terms of the catalyst warranty for the remaining term of the original warranty. The purchaser must provide the following information in order to receive a replacement catalyst under the terms of this limited warranty:

1. Name, address and telephone number.
2. Proof of original purchase date.
3. Date of failure of catalyst.
4. Any relevant information or circumstances regarding determination of failure.
5. In addition, the owner must return the failed catalyst.

## Exclusions & Limitations

1. This warranty is transferable; however, proof of original retail purchase is required.
  2. This warranty does not cover misuse of the stove. Misuse includes overfiring which will result if the stove is used in such a manner as to cause one or more of the plates to glow red. Overfiring can be identified later by warped plates and areas where the paint pigment has burned off. Overfiring in enamel fireplaces is identified by bubbling, cracking, chipping and discoloration of the porcelain enamel finish. CFM Specialty Home Products offers no warranty on chipping of enamel surfaces. Inspect your woodburning stove prior to accepting it for any damage to the enamel.
  3. This warranty does not cover misuse of the stove as described in the Owner's Guide, nor does it cover an stove which has been modified unless authorized by a CFM Specialty Home Products representative in writing. This warranty does not cover damage to the stove caused by burning salt saturated wood, chemically treated wood, or any fuel not recommended in the Owner's Guide.
  4. This warranty does not cover a stove repaired by someone other than a Vermont Castings Authorized Dealer.
  5. Damage to the unit while in transit is not covered by this warranty but is subject to a claim against the common carrier. Contact Vermont Castings Authorized Dealer from whom you purchased your stove or CFM Specialty Home Products if the purchase was direct. (Do not operate the stove as this may negate the ability to process the claim with the carrier.)
  6. Claims are not valid where the installation does not conform to local building and fire codes or, in their absence, to the recommendations in our Owner's Guide.
  7. The salt air environment of coastal areas, or a high-humidity environment, can be corrosive to the porcelain enamel finish. These conditions can cause rusting of the cast iron beneath the porcelain enamel finish, which will cause the porcelain enamel finish to flake off. This warranty does not cover damage caused by a salt air or high-humidity environment.
  8. CFM Specialty Home Products shall have no obligation to enhance or update any unit once manufactured.
- IN NO EVENT SHALL CFM SPECIALTY HOME PRODUCTS BE LIABLE FOR INCIDENTAL AND CONSEQUENTIAL DAMAGES. ALL IMPLIED WARRANTIES, INCLUDING THE IMPLIED WARRANTIES OF MERCHANTABILITY AND FITNESS, ARE LIMITED TO THE DURATION OF THIS WRITTEN WARRANTY. THIS WARRANTY SUPERCEDES ALL OTHER ORAL OR WRITTEN WARRANTIES.
- Some states do not allow the exclusion or limitations of incidental and consequential damages or limitations on how long an implied warranty lasts, so the above limitations may not apply to you. This warranty gives you specific rights and you may have other rights which vary from state to state.

## How to Obtain Service

If a defect is noted within the warranty period, the customer should contact a Vermont Castings Authorized Dealer or CFM Specialty Home Products if the purchase was direct with the following information:

1. Name, address, and telephone number of the purchaser.
  2. Date of purchase.
  3. Serial number from the label on the back.
  4. Nature of the defect or damage.
  5. Any relevant information or circumstances, e.g., installation, mode of operation when defect was noted.
- A warranty claim will then start in process. CFM Specialty Home Products reserves the right to withhold final approval of a warranty claim pending a visual inspection of the defect by authorized representatives.

## **CFM Specialty Home Products**

410 Admiral Blvd. • Mississauga, Ontario, Canada L5T 2N6 • 905-670-7777  
[www.majesticproducts.com](http://www.majesticproducts.com) • [www.vermontcastings.com](http://www.vermontcastings.com)

© CFM Specialty Home Products