

Sequoia

Model 2160

Homeowner's Installation and Operating Manual

SAFETY NOTICE

If this Sequoia is not properly installed, operated, and maintained, a house fire may result. For safety, follow all installation, operation and maintenance directions. Contact local building officials about restrictions and installation inspection requirements in your area.

CFM Specialty Home Products

410 Admiral Blvd. • Mississauga, Ontario, Canada L5T 2N6 • 905-670-7777
www.majesticproducts.com • www.vermontcastings.com

DO NOT DISCARD THIS MANUAL: Retain for future use

Welcome

Congratulations on your choice of a Dutchwest Sequoia. With this purchase, you have made a commitment to make the hearth a place of warmth, beauty and comfort in your home. At CFM Specialty Home Products, we share that joy and appreciation for the hearth, and we show it in all our cast iron stoves and fireplaces.

As you become acquainted with your new stove or fireplace, you will find that its visual appearance is matched by its functionality, due to cast iron's unique ability to absorb and radiate heat.

Also, Dutchwest products are among the cleanest-burning wood stoves and fireplaces available today. And as an owner of a Dutchwest stove or fireplace, you are making a strong statement for pollution-free energy. But clean burning depends on both the manufacturer and the operator. Please read this manual carefully to understand how to operate your stove or fireplace properly.

At CFM Specialty Home Products, we are equally committed to your satisfaction as a customer. That is why we maintain an exclusive network of the finest dealers in the industry. These dealers are chosen for their expertise and dedication to customer service. They are factory-trained to know the most minute detail of every Dutchwest product. Feel free to contact your local Authorized Dutchwest Dealer anytime you have a particular question about your stove or its performance.

Be assured that your cast iron Dutchwest stove or fireplace has been made with the utmost care and will provide you with many years of service.

This manual contains valuable instructions on the installation and operation of your Dutchwest stove or fireplace. It also contains useful information on maintenance and assembly of this product. We urge you to read the manual thoroughly and to keep this manual as a reference.

Sincerely,

All of us at Dutchwest

Table of Contents

Specifications	3
Installation	4
Assembly	16
Operation	18
Maintenance	23
Warranty	33

Accessories

- #6061 Rear Heat Shield
- #6062 Bottom Heat Shield
- #0134 Fire Screen

Proposition 65 Warning: Fuels used in gas, woodburning or oil fired appliances, and the products of combustion of such fuels, contain chemicals known to the State of California to cause cancer, birth defects and other reproductive harm. California Health & Safety Code Sec. 25249.6

This manual describes the installation and operation of the Sequoia Model 2160 catalytic-equipped wood heater. This heater meets the U.S. Environmental Protection Agency's emission limits for wood heaters sold after July 1, 1990. Under specific test conditions this heater has been shown to deliver heat at a rate ranging from 10,400 to 31,700 Btu's/Hr. A Sequoia equipped with an 8" (200mm) flue collar also burns coal. Coal-burning in the Sequoia is not allowed with the 6" (150mm) flue collar. In addition, the catalytic combustor must be removed before burning coal. In addition to directions on installation and operation, this manual includes directions on maintenance and assembly.

We recommend that you hire a professional solid fuel stove installer to install your stove, or to advise you on the installation should you attempt to install it yourself.

The Sequoia has been tested and is listed by Warnock Hersey of Middleton, Wisconsin. The test standards for the Sequoia equipped with a 8" (200mm) flue collar are ANSI/UL 1482 and ANSI/UL 737 for the United States and CAN/CSA-B366.2 for Canada. The Sequoia equipped with a 6" (150mm) flue collar is not tested to ANSI/UL 737 and should not be used in conjunction with fireplace screen. The Sequoia is not listed for installation in mobile homes.

Specifications

Sequoia, Model 2160

Range of heat output 10,400 to 31,700 Btu's/hr.***
 Maximum heat output 50,000 Btu's/hr.****
 Maximum burn time 8 hours*
 Area heated** 1,000-2,000 Square feet (65-130m²)
 Log lengths 23" (580mm)
 Loading Side or Front
 Chimney Flue Size 6" (150mm) or 8" (203mm)
 Flue exit position Reversible, Top or Rear
 Weight 540 lbs. (245kg.)
 Air Control 3 controls
 Width 26" (660mm)
 Depth 15½" (395mm)
 Height
 w/6" standard legs Top exit: 29½" (750mm)
 Rear exit: 30½" (775mm)
 w/Pedestal Top exit: 32¾" (835mm)
 Rear exit: 33¾" (855mm)

* General guidelines only; may vary with fuel type, moisture content, load size and installation variables.
 **These values are based on operation in building-code conforming homes under typical winter climate conditions in New England. If your home is of nonstandard construction (e.g., unusually well-insulated, not insulated, built underground, etc.) or if you live in a more severe or more temperate climate, these figures may not apply. Since so many variables affect stove sizing, consult your local dealer to determine realistic expectations for your home.
 *** These values were obtained under specific laboratory test conditions using Douglas fir dimensional lumber test fuel.
 **** These values can vary depending on how the stove is operated, the type and moisture content of the fuel used, as well as the design, construction and climate location of your home. Figures shown are based on maximum fuel consumption obtained under laboratory conditions using cordwood fuel and on average wood stove efficiencies.

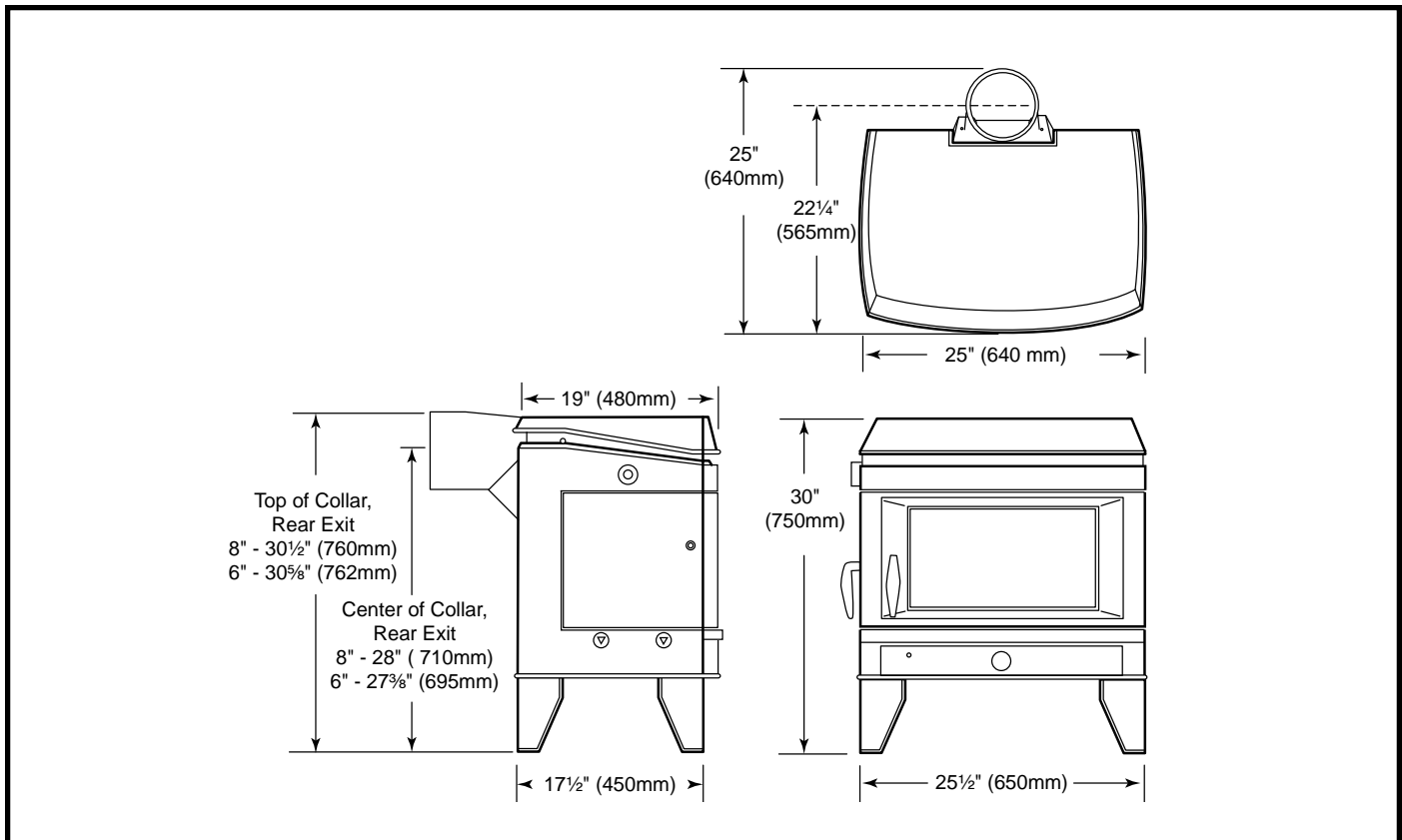

Fig. 1 Sequoia specifications.

Installation

SAFETY NOTICE: IF YOUR SEQUOIA HEATER IS NOT PROPERLY INSTALLED, OPERATED AND MAINTAINED, A HOUSE FIRE MAY RESULT. FOR SAFETY, FOLLOW ALL INSTALLATION, OPERATION AND MAINTENANCE DIRECTIONS. CONTACT LOCAL BUILDING OFFICIALS ABOUT RESTRICTIONS AND INSTALLATION INSPECTION REQUIREMENTS IN YOUR AREA.

Before you begin the installation, review your plans to confirm that:

- Your stove and chimney connector will be far enough from combustible materials to meet all clearance requirements.
- The floor protector is large enough and is constructed properly to meet all requirements.
- You have obtained all necessary permits from local authorities.

Your local building official is the final authority for approving your installation as safe and for determining that it meets local and state codes.

The metal label permanently attached to the back of the stove indicates that it has been tested to current UL and ULC standards, and gives the name of the testing laboratory. Clearance and installation information is also printed on the label. Local authorities generally will accept the label as evidence that, when the stove is installed according to the information on the label and in this manual, the installation meets codes and can be approved.

Codes vary in different areas, however. Before starting the installation, review your plans with the local building authority. Your local dealer can provide any additional information needed.

For any unresolved questions about installation, refer to the National Fire Protection Association's publication ANSI/NFPA 211-1988 Standard For Chimneys, Fireplaces, Vents and Solid Fuel Burning Appliances. In Canada, the equivalent publication is CSA CAN-B365, Installation Code for Solid Fuel Burning Appliances and Equipment. These standards are the basis for many national codes. They are nationally recognized and are accepted by most local authorities. Your local dealer or your local building official may have a copy of these regulations.

Important: Failure to follow these installation instructions may result in a dangerous situation, including a chimney or house fire. Follow all instructions exactly, and do not allow makeshift compromises to endanger property and personal safety.

Chimney Types

Your Sequoia must be connected to a sound masonry chimney that meets local codes, a relined masonry chimney that meets local codes, or to an approved prefabricated metal chimney. Whatever kind you use, the chimney and chimney connector must be in good condition and kept clean.

Masonry Chimneys

If you use an existing masonry chimney, it must be inspected to ensure safe condition before the stove is installed. Your local professional chimney sweep, building inspector, or fire department official will be able either to make the inspection or to direct you to someone who can.

An inspection of the chimney must confirm that it has a lining. Do not use an unlined chimney. The chimney should also be examined for cracks, loose mortar, other signs of deterioration, and blockage. Repair any defects before the chimney is used with your stove.

Unused openings in an existing masonry chimney must be sealed with masonry to the thickness of the chimney wall, and the chimney liner should be repaired. Openings sealed with pie plates or wallpaper are a hazard and should be sealed with mortar or refractory cement. In the event of a chimney fire, flames and smoke may be forced out of these unused thimbles.

The chimney should be thoroughly cleaned before use.

A newly-built masonry chimney must conform to the standards of your local building code or, in the absence of a local code, to a recognized national code. Masonry chimneys must be lined, either with code-approved masonry or pre-cast refractory tiles, stainless steel pipe, or a code-approved, "poured-in-place" liner. The chimney's clean-out door must seal tightly.

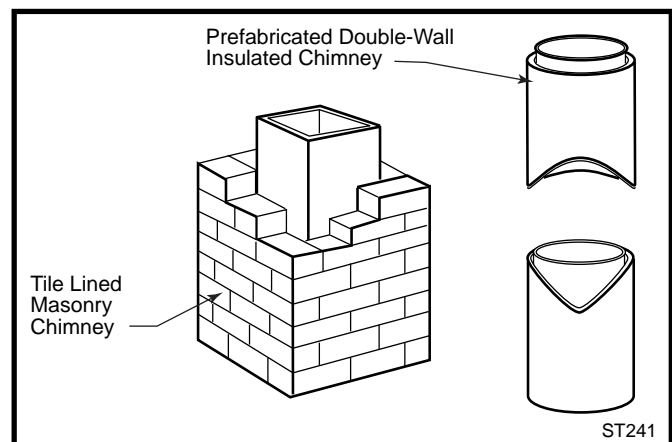

Fig. 2 If in sound condition and approved for use, either a masonry or a prefabricated chimney may be used.

Prefabricated Chimneys

A prefabricated metal chimney must be one tested and listed for use with solid-fuel burning appliances to the High-Temperature (H.T.) chimney Standard UL-103-1985 (2100°F.) for the United States, and High Temperature (650°C) Standard ULC S-629 for Canada.

DO NOT CONNECT THIS UNIT TO A CHIMNEY FLUE SERVING ANOTHER APPLIANCE.

Chimney Size

A Sequoia with an 8" (203mm) flue collar is approved for venting into a masonry chimney with a nominal flue size of 8" x 8" (203 x 203mm), and into a round flue size of 8" (203mm). A Sequoia with a 6" (152mm) flue collar is approved for venting into a masonry chimney with a nominal flue size of 8" x 8" (203 x 203mm), and into a round flue size of 6" (152mm).

Whatever the flue collar size, a Sequoia may be vented into larger chimneys as well. However, chimneys with larger liners and particularly those with liners larger than 8" x 12" (203 x 305mm) may experience rapid cooling of smoke and reduction in draft, especially if they are located outside the home. These large chimneys may need to be insulated or have their flues relined for proper stove performance.

Accessories to help make the connection between stainless steel chimney liners and your Sequoia are available through your local dealer.

Chimney Height

Altitude affects chimney performance. Refer to the chart below for suggested chimney heights at various altitudes. Chimney height should be measured from the flue collar to the top of the chimney. The recommended minimum chimney height is 16' (4.9m).

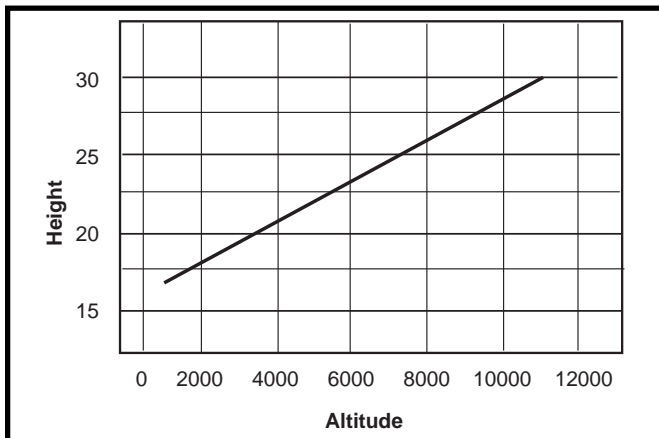

Fig. 3 Chimney height requirements with 6" chimney and/or chimney connector.

The chimney should extend at least 3' (914mm) above the highest point where it passes through the roof, and at least 2' (610mm) higher than any part of a building within 10' (3m).

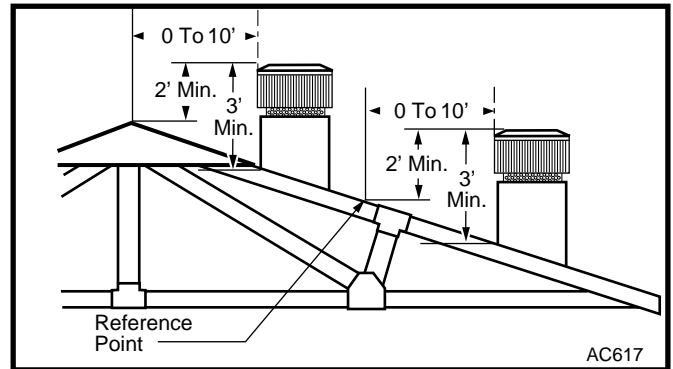

Fig. 4 The 2/3/10 rule for chimneys.

Chimney Connector Guidelines

The chimney connector is the single-wall pipe that connects the stove to the chimney. The chimney itself is a masonry or prefabricated structure that encloses the flue. Chimney connectors are used only to make the connection from the stove to the chimney.

Do not pass the chimney connector through a combustible wall or ceiling, or through an attic, a closet or any similar concealed space. If passage through a combustible wall is unavoidable, follow the recommendations in the following section on Wall Pass-Throughs.

WARNING: Do not use double-wall chimney connectors with the Sequoia unless they have been specifically tested and listed for use with this appliance. Use of double-wall chimney connectors that have not been tested and listed for use with the Sequoia may result in temperatures exceeding the limits established by the test standards ANSI/UL-1482 or ULC S627. A potential hazard may result, including a house fire.

Use chimney connector that is 24 gauge steel or heavier, with a diameter of 8" (203mm) for an 8" (203mm) flue collar or 6" (152mm) for the 6" (152mm) flue collar.

Install the chimney connector not less than 18" (457mm) from the ceiling. Keep the passage as short and direct as possible, with no more than two 90° turns. Slope horizontal runs of connectors upward 1/4" per foot (20mm per meter) going from the stove toward the chimney. The recommended maximum length of horizontal run is 3' (914mm), and the total length of chimney connector should be no longer than 8' (2.4m).

In cathedral ceiling installations, extend the prefabricated chimney downward to within 8' (2.4 meters) of the

stove. The entire chimney connector should be exposed and accessible for inspection and cleaning. Do not use galvanized chimney connector; it cannot withstand the high temperatures that can be reached by smoke and exhaust gases and it may release toxic fumes under high heat.

Assembling the Chimney Connector

SAFETY NOTE: Always wear gloves and safety goggles when drilling, cutting or joining sections of chimney connector.

- Beginning at the flue collar of the stove, assemble the chimney connector. Insert the first crimped end into the stove's flue collar, and keep each crimped end pointing toward the stove. Using the holes in the flue collar as guides, drill 1/8" (3mm)

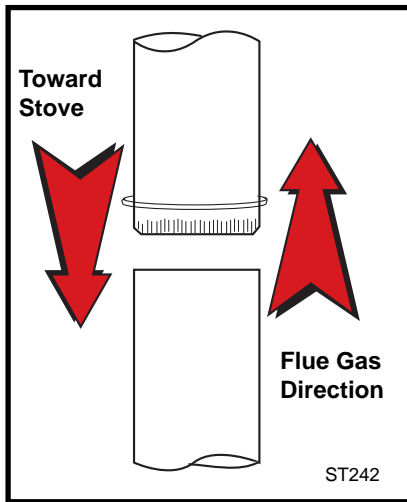

Fig. 5 Crimped sections always point toward the stove so that any liquid condensation will not leak out.

- holes in the bottom of the first section of chimney connector and secure it to the flue collar with three #10 x 1/2" sheet metal screws.
- Secure each joint between sections of chimney connector, including telescoping joints, with at least three sheet metal screws. The predrilled holes in the top of each section of chimney connector serve as guides when you drill 1/8" (3mm) holes in the bottom of the next section.
- Secure the chimney connector to the chimney. Instructions for various installations follow.
- Be sure the installed stove and chimney connector are correct distances from nearby combustible material.

NOTE: Special slip pipes and thimble sleeves that form telescoping joints between sections of chimney connector are available to simplify installations. They can eliminate the need to cut individual connector sections. Consult your local dealer about these special pieces.

Securing the Connector to a Prefabricated Chimney

Follow the installation instructions of the chimney manufacturer exactly as you install the chimney. The manufacturer of the chimney will supply the accessories to support the chimney, either from the roof of the house, at the ceiling of the room where the stove is installed, or from an exterior wall.

Special adapters are available from your local dealer to make the connection between the prefabricated chimney and the chimney connector. The top of such adapters attach directly to the chimney or to the chimney's ceiling support package, while the bottom of the adapter is screwed to the chimney connector.

These adapters are designed so the top end will fit outside the inner wall of the chimney, and the bottom end will fit inside the first section of chimney connector. Any soot or creosote falling from the inner walls of the chimney will stay inside the chimney connector.

Securing the Connector to a Masonry Chimney

The Sequoia may be connected to either a freestanding masonry chimney or a masonry fireplace chimney.

Freestanding Installations

If the chimney connector must pass through a combustible wall to reach the chimney, follow the recommendations in the wall pass-through section that follows.

The opening through the chimney wall to the flue (the "breach") must be lined with either a ceramic or metal cylinder, called the "thimble", which is securely cemented in place. (Fig. 5) Most chimney breeches incorporate thimbles, but check to be sure the fit is snug and the joint between thimble and chimney wall firmly cemented.

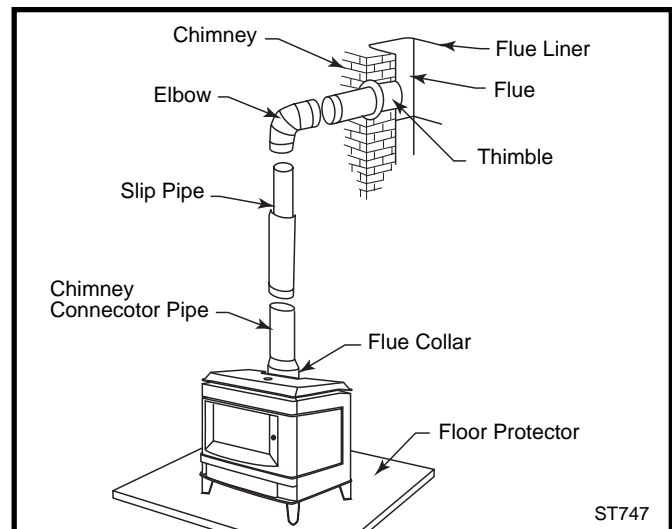

Fig. 6 Installing the chimney connector to a lined masonry chimney.

A special piece called the "thimble sleeve," slightly smaller in diameter than the standard connector and most thimbles, will ease the removal of the chimney connector system for inspection and cleaning. (Fig. 6) Thimble sleeves should be available from your local dealer.

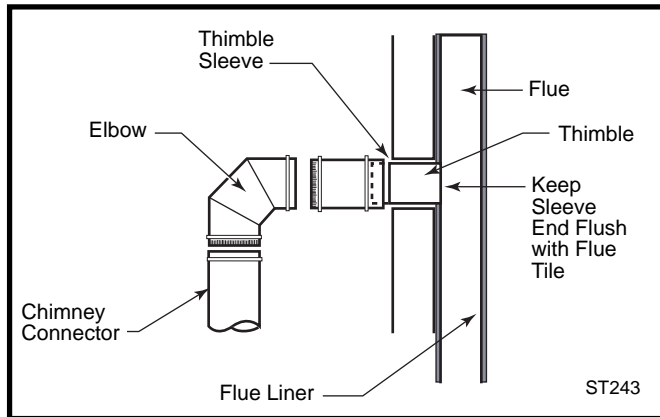

Fig. 7 The thimble, made of either ceramic or metal, must be cemented in place securely.

To install a thimble sleeve, slide it into the breach until it is flush with the inner flue wall. Do not extend it into the actual flue passage, as that could interfere with the draft.

The thimble sleeve should protrude 1-2" (25-50 mm) into the room. Use furnace cement and thin gasketing to seal the sleeve in place in the thimble. Secure the chimney connector to the outer end of the sleeve with sheet metal screws.

Fireplace Installations - Above the Fireplace

In this installation, the chimney connector rises from the stove, turns ninety degrees, and goes back into the fireplace chimney. The liner of the fireplace chimney should extend at least to the point at which the chimney connector enters the chimney. Follow all the guidelines for installing a chimney connector into a freestanding masonry chimney, and pay special attention to these additional points:

- Check the stove and chimney connector clearances to combustible mantel or trim materials. Use the necessary combination of mantel, trim, and connector heat shields to provide the required clearances. (Fig. 8)
- Double-check connector clearance from the ceiling.
- The fireplace damper must be closed and sealed to prevent room air from being drawn up the flue, reducing the draft. However, it must be possible to re-open the damper to inspect or clean the chimney.

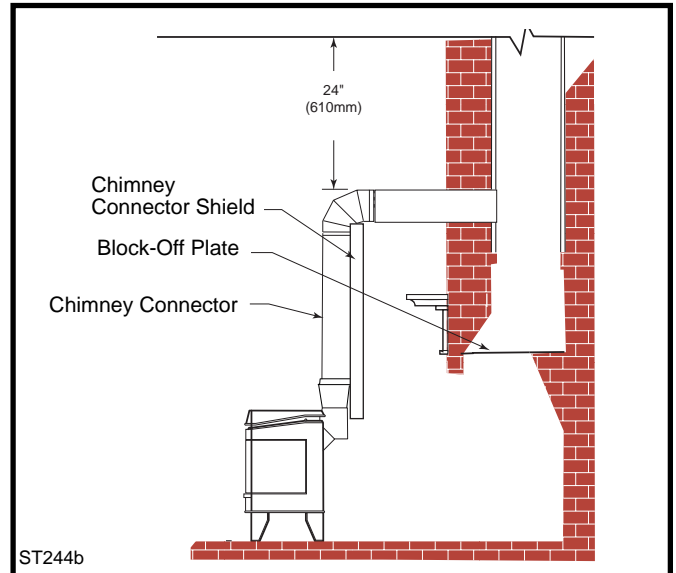

Fig. 8 The connector enters flue above the fireplace. If the clearance between the chimney connector and either the mantel and/or the ceiling is inadequate, special protective shields will be required.

Fireplace Installations - Through the Fireplace

If the height of your fireplace opening is at least 30" (762mm), you may install a Sequoia through the opening using a "positive connection" kit available from your local dealer. These kits ensure a tight fit between the stove flue collar and the chimney flue.

Fireplace installations, whether connected to the flue above or through the fireplace opening, have special clearance requirements to adjacent trim and the mantel. You will find the required safe clearances for Sequoia fireplace installation on Page 10.

Floor protection requirements also apply to fireplace installation. Be sure to review the floor protection requirements on Page 8.

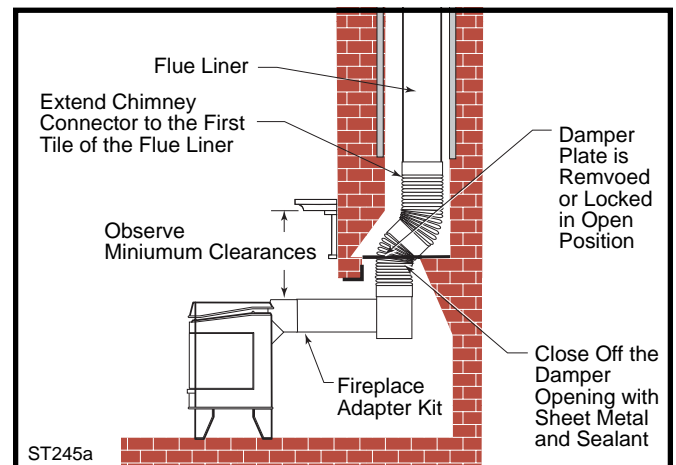

Fig. 9 The connector passes through the fireplace to enter flue. Special Fireplace Adapter Kits to simplify fireplace installations are available from your local dealer.

Wall Pass-Throughs

Whenever possible, design your installation so the connector does not pass through a combustible wall. If you must use a wall pass-through in your installation, check with your building inspector before you begin and construct it in accordance with local building codes. Also check with the chimney connector manufacturer for any specific requirements.

Accessories are available for use as wall pass-throughs. If using one of these, make sure it has been tested and listed for use as a wall pass-through.

In the United States, the national Fire Protection Association (NFPA) has established guidelines for passing chimney connectors through combustible walls. Many building code inspectors follow these guidelines when approving installations.

Figure 10 shows one NFPA-recommended method. All combustible material in the wall is cut away a sufficient distance from the single-wall connector to provide the required 12" (305mm) clearance for the connector. Any material used to close up the opening must be noncombustible.

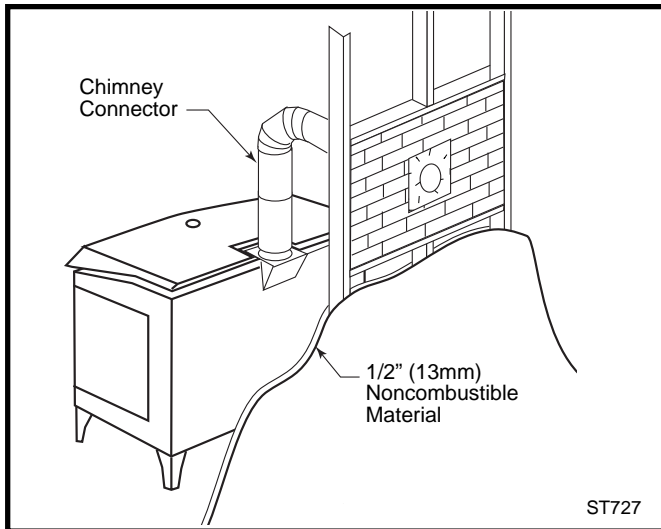

Fig. 10 Wall pass-through enclosed with noncombustible materials.

Three other methods are also approved by the NFPA. These are:

- Using a section of double-wall chimney with a 9" clearance to combustibles.
- Placing a chimney connector pipe inside a ventilated thimble, which is then separated from combustibles by 6" of fiberglass insulating material.
- Placing a chimney connector pipe inside a section of 8" diameter, solid-insulated, factory-built chimney, with 2" of air space between the chimney section and combustibles.

In Canada, the Canadian Standards Association has established different guidelines. Figure 11 shows one method, in which all combustible material in the wall is cut away to provide the required 18" (457mm) clearance for the connector. The resulting space must remain empty. A flush-mounted sheet metal cover may be used on one side only. If covers must be used on both sides, each cover must be mounted on noncombustible spacers at least 1" (25mm) clear of the wall. Your local dealer or your local building inspector can provide details of other approved methods of passing a chimney connector through a combustible wall. In Canada, this type of installation must conform to CAN/CSA-B365, Installation Code for Solid Fuel Burning Appliances and Equipment.

NOTE: Do not vent your Sequoia into a factory-built (zero-clearance) fireplace. These appliances and their chimneys are specifically designed as a unit for use as fireplaces. It may void the listing or be hazardous to adapt them to any other use.

DO NOT CONNECT THE HEATER TO ANY AIR DISTRIBUTION DUCT OR SYSTEM.

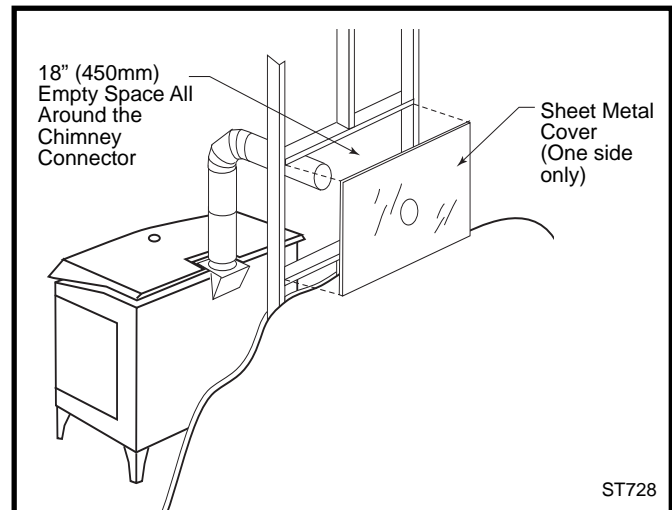

Fig. 11 Hollow wall pass-through.

Floor Protection

A tremendous amount of heat radiates from the bottom plate of your Sequoia stove. The floor area directly under and around the stove will require protection from radiant heat as well as from stray sparks or embers that may escape the firebox.

Heat protection is provided through the use of a Dutchwest Bottom Heat Shield. Spark and ember protection must be provided by a floor protector constructed with noncombustible material as specified. Most installations will require that the bottom heat shield be attached. Only when the stove is placed on a

completely noncombustible surface such as unpainted concrete over earth may be used without the heat shield.

Even when the bottom heat shield is installed, you must provide special protection to the floor beneath. For installation with the heat shield attached, use a noncombustible floor protector such as 1/4" non-asbestos mineral board or equivalent, or 24 gauge sheet metal. The floor protector may be covered with a decorative noncombustible material if desired. Do not obstruct the space under the heater.

Protection requirements vary somewhat between the United States and Canada as follows:

U.S. Installations: The floor protector is required under the stove and must extend at least 16" from the front and left (loading door) side of the stove, and at least 6" from the right side and rear. (Fig. 12) It must also extend under the chimney connector and 2" to either side. Refer to Figure 12 for minimum noncombustible floor protection dimensions.

To meet these requirements, a floor protector must be at least 48" wide and 42" deep.

In Canada: a noncombustible floor protector is required under the heater also. The floor protector must extend 18" (457mm) from the front and left (loading door) side of the stove, and at least 6" (150mm) from the right side and rear. (Fig. 12) It must also extend under the chimney connector and 2" to either side. Refer to Figure 12 for minimum noncombustible floor protection dimensions.

In addition, a pad measuring 18" (457mm) wide by 24" (610mm) long consisting of 1/2" (13mm) thick rigid insulation board with a K value of .23 or less (such as Carborundum Duraboard LD or Manville Ceraform 126) is also required; it must be centered and must extend 16" (406mm) in front of and 8" (203mm) under the unit. The floor protector may be covered with a noncombustible decorative material if desired. Do not obstruct the space under the heater.

To meet these requirements, a floor protector must be 50" (1270mm) wide and 44" (1118mm) deep.

Due to the side loading door, floor protector requirements call for more protection on the left side than on the right. If you wish a more balanced look, increase the other side of the hearth as well. **Do not reduce side protection under any circumstances.**

NOTE: In both the United States and Canada, no bottom heat shield is required when the optional pedestal base is used in place of the standard legs.

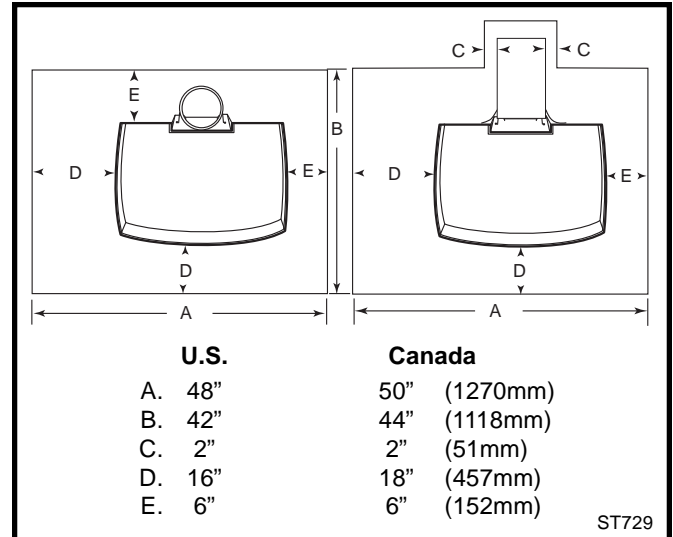

Fig. 12 Required floor protection dimensions.

Floor Protection for Fireplace

Do not assume that your fireplace hearth is completely noncombustible. Many fireplace hearths do not satisfy the "completely noncombustible" requirement because the brick or concrete in front of the fireplace opening is supported by heavy wood framing. Because heat passes readily through brick or concrete, it can easily pass through to the wood. As a result, such fireplace hearths can be a fire hazard and are considered a combustible floor. (Fig. 13)

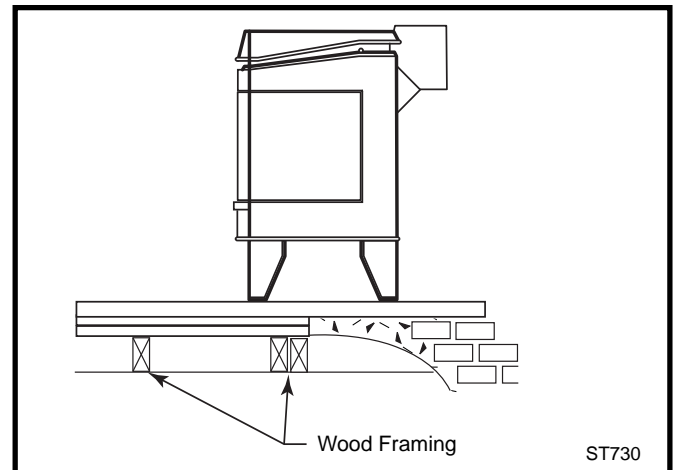

Fig. 13 Combustible supporting timbers may lie beneath fireplace hearths; such situations require additional floor protection.

For all fireplace installations, follow the floor protection guidelines described above. Keep in mind that many raised hearths will extend less than the required clearance from the front of the heater. In such cases, sufficient floor protection as described above must be added in front of the hearth to satisfy the minimum floor protector requirement from the front of the stove: 16" (406mm) in the United States and 18" (457mm) in Canada.

Hearth rugs do not satisfy the requirement for floor protection as they are not fire proof.

Fireplace installations also have special clearance requirements to the side walls, side decorative trim and fireplace mantel. Refer to the information on fireplace and mantel trim shields in this section.

Keep the Stove a Safe Distance from Surrounding Materials

Both a stove and its chimney connector radiate heat in all directions when operating. A safe installation requires that adequate *clearance* be maintained between the stove and nearby combustible materials to ensure that such materials do not overheat.

Clearance is the distance between either your stove or chimney connector, and nearby walls, floors, the ceiling, and any other fixed combustible surface. Keep furnishings and other combustible materials away from the stove as well. In general, a distance of 48" (1220 mm) must be maintained between the stove and moveable combustible items such as drying clothes, furniture, newspapers, firewood, etc. Keeping those clearance areas empty assures that nearby surfaces and objects will not overheat.

Safe Ways to Reduce Clearances

Your stove has specific clearance requirements that have been established through careful research and testing to UL and ULC standards.

Clearance requirements have been established to meet every installation possibility, and they involve the combination of basic variables:

- When the stove *has no* listed heat shield
- When the stove *has a* listed heat shield
- When the wall *has no* heat shield
- When the wall *has a* heat shield

In general, the greatest clearance is required when you locate a stove with no heat shield near a wall with no heat shield. The least clearance is required when both the stove and the wall have heat shields. Reducing a stove clearance may require a listed heat shield on the chimney connector as well, or a double-wall connector.

Clearances may be reduced only by means approved by the regulatory authority and in accordance with the clearances listed in this manual. The charts and sample installations that follow list all the clearances required for the various installation configurations of Sequoia.

Wall Shields

One way to reduce clearances is with a wall shield constructed of 24 gauge or heavier sheet metal, or of another noncombustible material such as 1/2" (13 mm)

insulation board such as Durock® or Wonderboard®, or common brick "laid on flat," with the 3½" (90 mm) side down.

Shields must be spaced out from the combustible surface 1" (25 mm) on noncombustible spacers, as in Figure 14. The spacers should not be directly behind the stove or chimney connector.

Air must be able to flow between the wall and the shield. At least 50% of the bottom 1" (25 mm) of the shield must be open, and the shield must be open at the top. (Fig. 14)

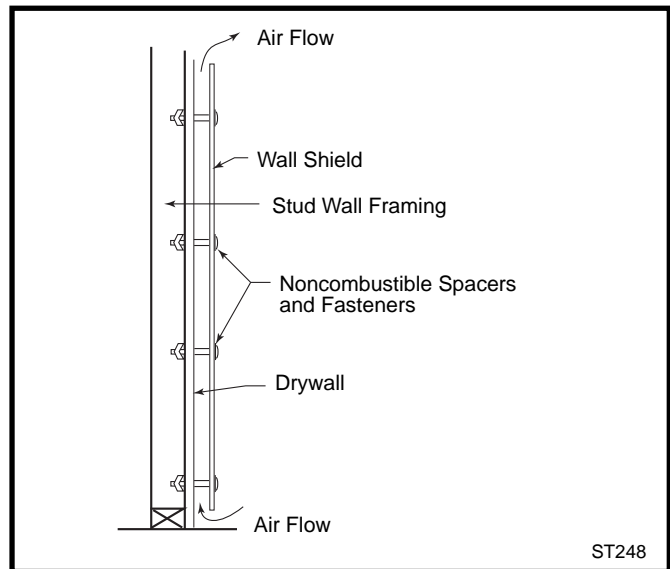

Fig. 14 Approved wall shield construction.

Fireplace Installations

A fireplace installation requires special clearance between the side of the stove and the right and left walls, between the side of the stove and the decorative side trim on the fireplace face, and between the top of the stove and the mantel.

Ventilated, noncombustible shields installed on noncombustible spacers 1" (25mm) away from the combustible surface may be used to reduce clearances. A mantel shield for the Sequoia must be at least 48" (1220mm) long, centered over the stove. Side trim shields must extend the full length of the trim.

In addition, a fireplace installation must observe the floor protection guidelines discussed previously.

The charts and illustrations that follow depict all the clearances required for the various installation configurations of the Sequoia.

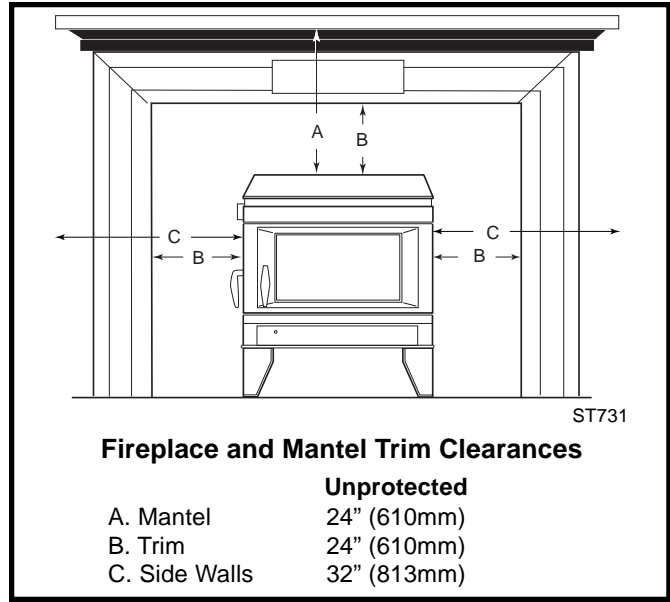

Fig. 15 Maintain clearances to combustible components of the mantelpiece.

Sequoia Clearance Chart

	Stove Clearance					
	Unprotected Surfaces			Protected Surfaces		
	Stove Installed Parallel to Wall		Stove in Corner	Stove Installed Parallel to Wall		Stove in Corner
	Side	Rear	Corners	Side	Rear	Corners
No stove heat shields¹	(A) 32" (813mm)	(B) 42" (1067mm)	(C) 36" (914mm)	(D) 16" (406mm)	(E) 26" (660mm)	(F) 20" (508mm)
Stove, top exit with rear heat shield, no connector heat shields	(G) 32" (813mm)	(H) 42" (1067mm)	(I) 36" (914mm)	(J) 16" (406mm)	(K) 26" (660mm)	(L) 20" (508mm)
Stove, top exit with rear heat shield, and heat shields on connector^{1,2,3}	(M) 32" (813mm)	(N) 20" (508mm)	(O) 26" (660mm)	(P) 16" (406mm)	(Q) 14" (356mm)	(R) 12" (305mm)
Stove, rear exit with rear heat shield only	(S) 32" (813mm)	(T) 20" (508mm)	N/A	(U) 16" (406mm)	(V) 14" (356mm)	N/A
	Chimney Connector Clearance					
	Unprotected Vertical Surfaces			Protected Vertical Surfaces		
	36" (914mm)			19" (483mm)		
No chimney connector heat shields	36" (914mm)			19" (483mm)		
Chimney connector heat shields installed ²	14" (356mm)			8" (203mm)		
	Clearance to Combustibles in Front of Stove					
	All Installations 48" (1219mm)					

1 All installations venting straight up to a factory-built chimney require a 24" (610mm) diameter or square ceiling heat shield. The ceiling heat shield should be 24 gauge sheet metal or equivalent mounted on 1" (25mm) noncombustible spacers 1" (25mm) below ceiling.

2 Shielding for a top exit stove must include a shield insert to protect the area behind the flue collar.

3 Chimney connector heat shields must extend to within 1" (25mm) or less of the ceiling heat shield for installations venting straight up to a factory-built chimney. Top exit installations using an elbow to vent to rear chimney connector must be shielded over entire vertical length.

Sequoia Clearance Diagrams

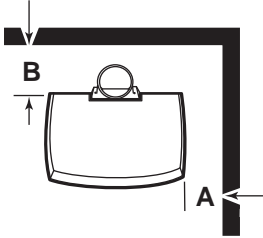
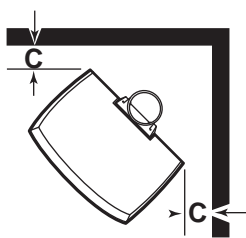
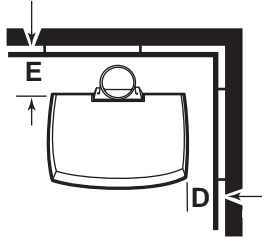
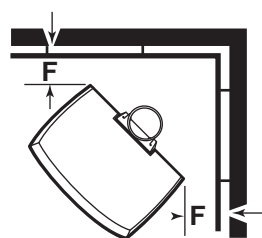
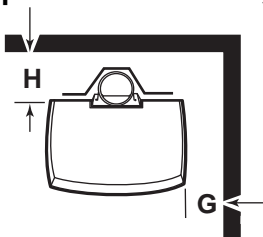
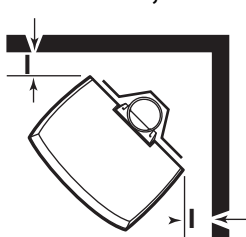
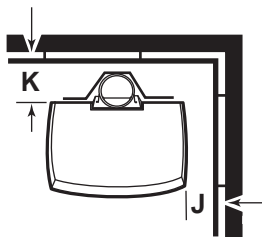
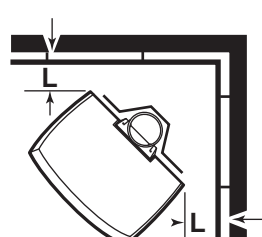
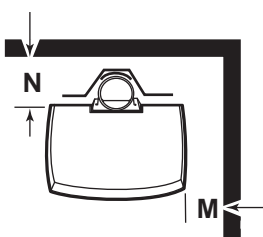
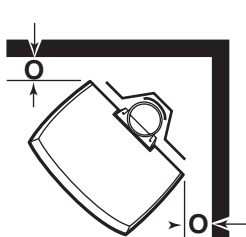
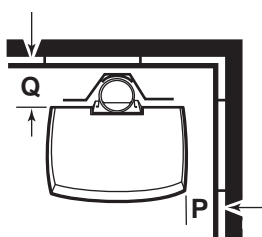
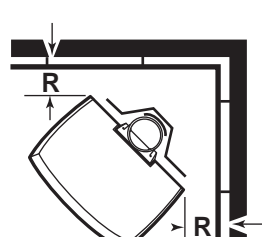
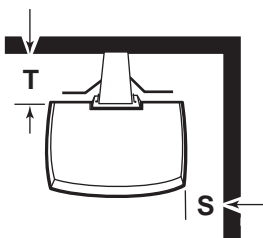
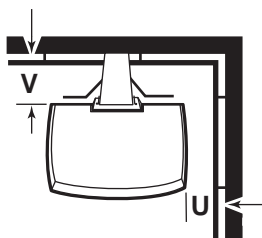
Unprotected Surfaces		Protected Surfaces	
Stove Installed Parallel to Wall	Stove in Corner	Stove Installed Parallel to Wall	Stove in Corner
Top Exit Installations, no heat shields			
			
Top Exit Installations, rear heat shield, no connector heat shields.			
			
Top Exit Installations, rear heat shield, heat shield on connector.			
			
Rear Exit Installations, rear heat shield only.			
	N/A		N/A

ST732

Wall Shield Requirements for Common Sequoia Installations

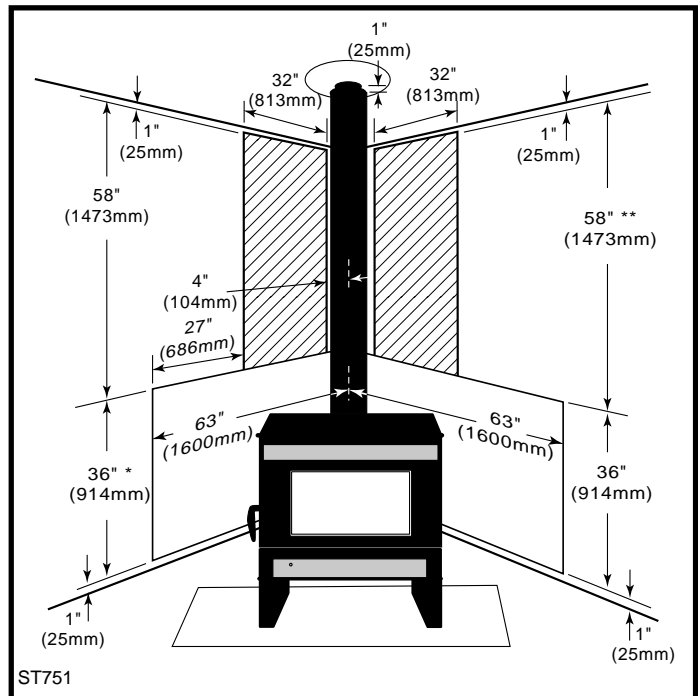
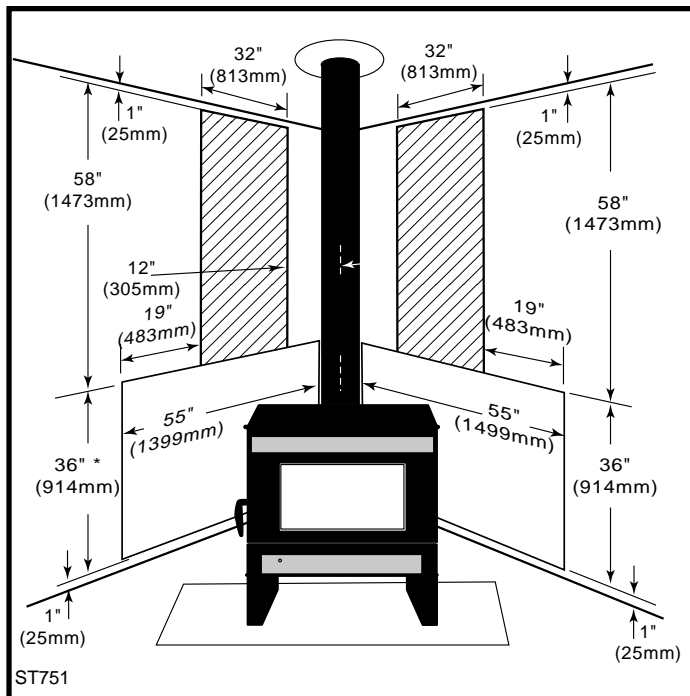
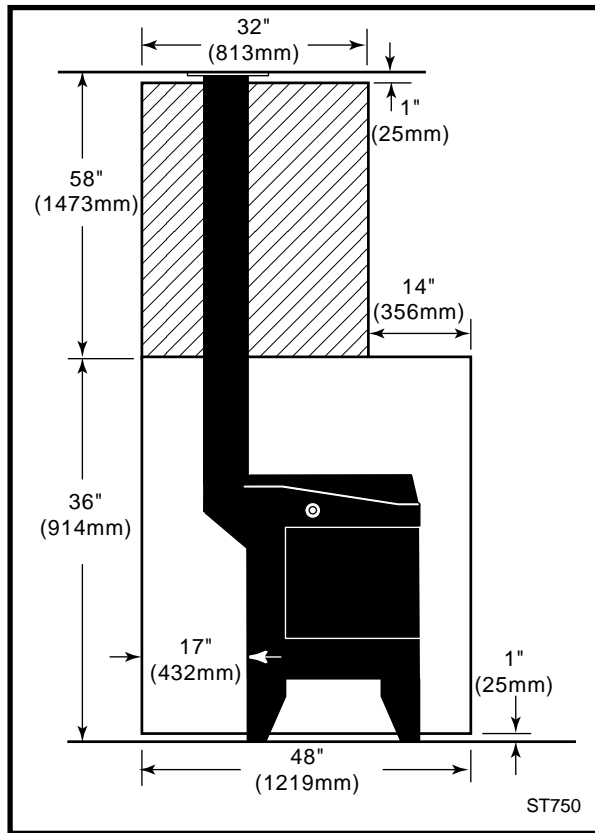
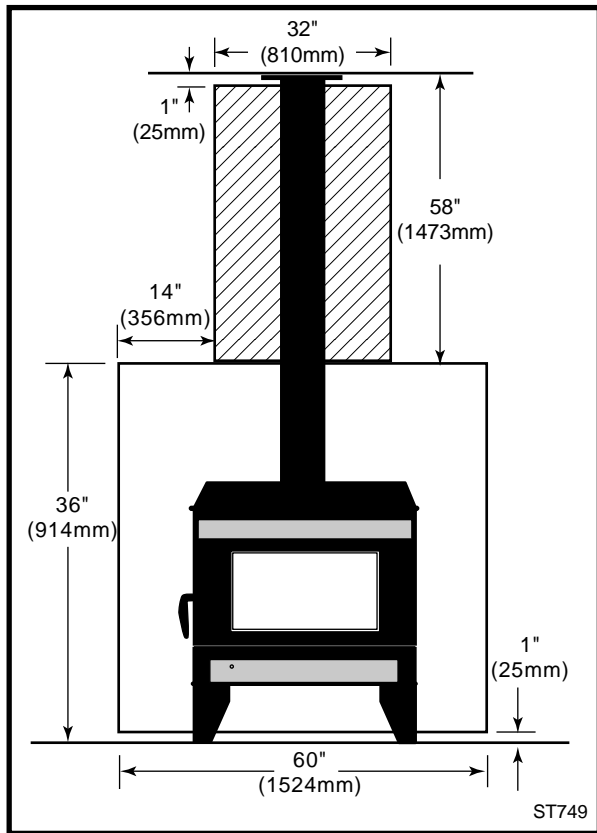

* When optional pedestal is used instead of standard legs, the wall shield height is 39½" (1003mm).

** Or within 1" of ceiling.

Distance from the Center of the Flue Collar to the Wall in Top Exit Sequoia Installations

The information on this page is helpful in planning stove placement for top exiting installations, particularly those installations with chimneys that pass through the ceiling. However, this is not a clearance chart. For clearance information, refer to the clearance chart on Page 12. The terms "Side" and "Rear" refer to the distance from the center of the flue collar to the respective wall. The term "Front" refers to the distance from the center of the flue collar to the front edge of the hearth. The asterisk indicates U.S./Canada.

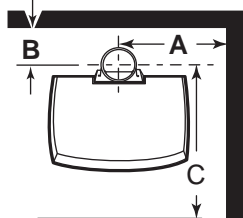
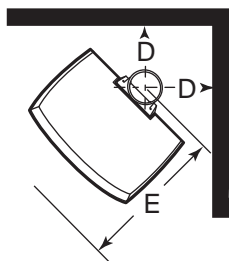
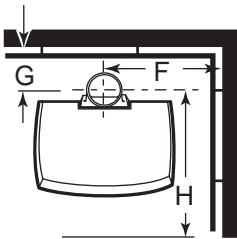
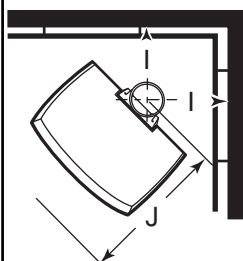
Sequoia WITHOUT Stove and Chimney Connector Heat Shields									
Unprotected Surfaces					Protected Surfaces				
Stove Installed Parallel to Wall			Stove in Corner		Stove Installed Parallel to Wall			Stove in Corner	
Side (A)	Rear (B)	Front (C)	Corners (D)	Front (E)	Side (F)	Rear (G)	Front (H)	Corners (I)	Front (J)
45" 1143mm	20" 508mm	37" / 39"* 940/991mm	44" 1118mm	37" / 39" * 940/991mm	29" 737mm	23" 584mm	37" / 39"* 940/991mm*	28" 711mm	37" / 39"* 940/991mm*
									

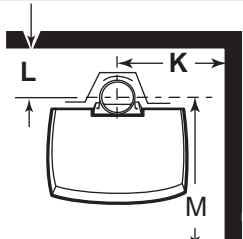
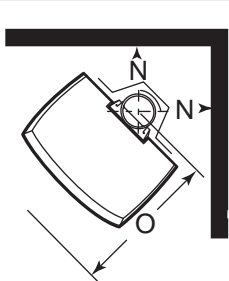
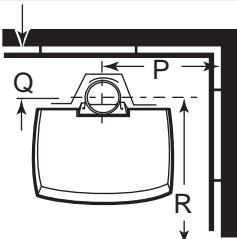
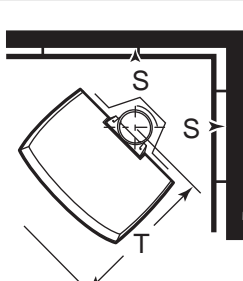
Sequoia WITH Stove and Chimney Connector Heat Shields									
Unprotected Surfaces					Protected Surfaces				
Stove Installed Parallel to Wall			Stove in Corner		Stove Installed Parallel to Wall			Stove in Corner	
Side (K)	Rear (L)	Front (M)	Corners (N)	Front (O)	Side (P)	Rear (Q)	Front (R)	Corners (S)	Front (T)
45" 1143mm	18" 457mm	37" / 39"* 940/991mm	34" 864mm	37" / 39"* 940/991mm	29" 737mm	12" 305mm	37" / 39"* 940/991mm*	20" 508mm	37" / 39"* 940/991mm*
									

Assembly

Unpack the Parts

Remove all loose parts from the firebox and the ash pan. Check to make sure all the parts are included and intact. You should have received:

- 1 fully assembled heater body, (with catalytic burner installed in its chamber below the stove top)
- 4 legs
- 1 Installed ash pan containing:
 - 1 Replacement Interam gasket, for combustor
 - 1 Ceramic Handle, for use on the doors and damper
 - 1 Brass Handle, for use on dial dampers
 - 1 bag of hardware used for assembly, including the following:
 - To attach the legs to the stove:
 - (4) 1/4-20 x 1" hex head bolts
 - (4) 1/4" washers
 - For tightening the door latch:
 - (1) Allen wrench, 5/32"
 - also...
 - (1) Spring, which fit inside the square socket in the iron part of the door handles, and will push the handle off the stove in case you forget to remove it after adjusting the dial dampers. This keeps the handles from getting hot.

The hardware in the stove is in standard US sizes. Most bolts are 1/4-20 and 7/16 heads.

If any parts are missing or damaged, immediately notify your Dutchwest dealer for replacements. Do not install your stove without having all necessary parts or by using damaged parts.

Attach the Legs and Heat Shield*

Since you have already received delivery of your Sequoia, you are aware of how heavy it is. To safely accomplish the setup and installation of the Sequoia, you should have two or more strong assistants to help move it.

Place the stove on its back on a soft surface such as a couple of old blankets. Tilt it carefully. Protect surrounding carpet with an old blanket or sheet.

First, loosely install a bottom heat shield bracket and leg to each corner of the stove. Place a 1/4-20 x 1" bolt through the unthreaded hole in the bracket so the bracket's threaded hole will extend below the leg. Position the leg, and fasten it to the stove finger-tight with bolt. Repeat this step for each of the four legs.

*Bottom heat shields are standard only on stoves sold in Canada.

Next, fasten the bottom heat shield to the brackets, adjusting the legs as needed to make the shield fit. Tighten the shield securely, then use a wrench to tighten the leg bolts firmly. Now raise the stove onto its legs.

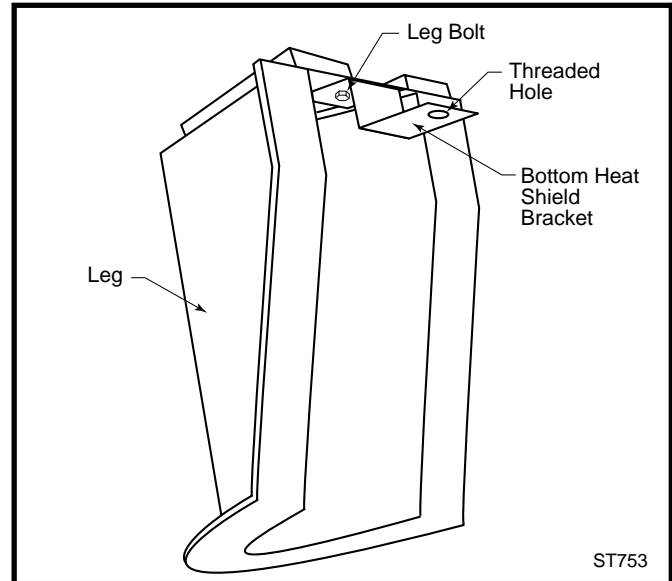

Fig. 16 Attach bottom heat shield brackets and legs to stove using 1" bolts.

Install the Fittings

To install the catalytic probe:

- Locate the hole in the top of stove.
- Insert a 1/4" drill bit in the hole and rotate it with your fingers to clear a path for the probe through the fragile refractory material.
- Insert the probe stem into the stove top and through the prepared opening.

Your stove has been shipped with grate covers installed. These must remain installed when burning wood, but should be removed for burning coal.

The hardware in your stove is in standard US sizes. Most bolts are 1/4"-20, with 7/16" heads. Some of the hex-head bolts have metric heads. Use wither a 3/8" (10mm) wrench, or an 8mm wrench or pliers if you are attaching a blower to the stove.

The multipurpose brass handle will operate the two spin-dial air controls, the doors and the stove damper.

Install Air Duct for Outside Air

If your installation will include outside air for combustion, follow these directions for attaching the three inch duct to the stove:

- Screw a #10 x 1/2" sheet metal screw into the duct. Tighten the screw, then back it off two turns.
- The outside air port on the back of the stove has a slot at the 10:00 o'clock position. Align the screw in the duct pipe with the slot and insert the pipe. Turn 1/4 turn, clockwise. This locks the pipe securely in position.

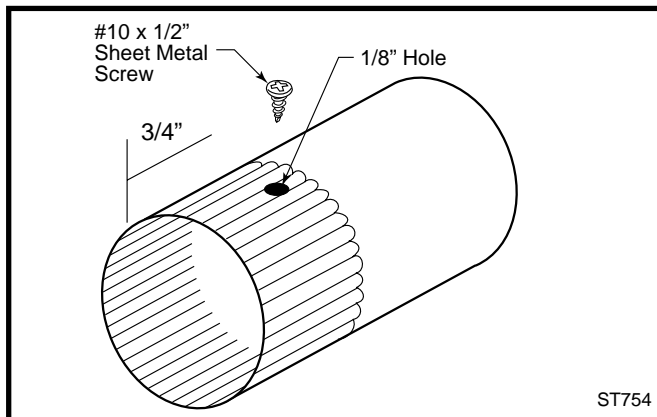

Fig. 17 Drill a 1/8" hole in the crimped end of the three inch pipe duct, 3/4" from the end.

Operation

The Sequoia Controls

Air Controls

The Sequoia has three air controls that regulate the amount of air drawn into the stove. Generally, more air entering the stove makes the fire burn hotter and faster, while less air prolongs the burn.

The **Primary Air Control** is the lever located on the upper right side of the stove front and is the primary source of air for starting and maintaining wood fires. It is always closed when burning coal. It opens when moved clockwise and closes when moved counterclockwise.

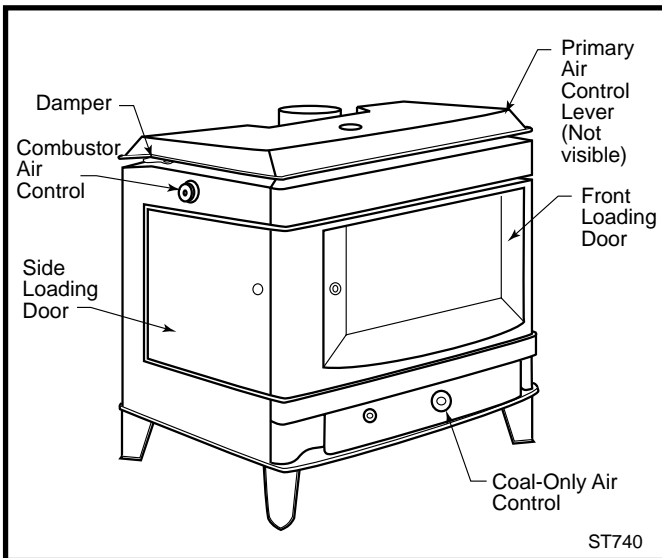

Fig. 18 All stove controls are conveniently accessible and easy to regulate.

The **Combustor Air Control** is located on the left side of the stove, above the side loading door, and delivers preheated air to a strategic internal site to aid catalytic combustion when burning wood. This control is closed completely when burning coal. Turn counterclockwise to open and clockwise to close.

The **Coal-only Air Control** is positioned on the access door to the ash drawer compartment. It is the air supply for starting and maintaining coal fires. This control must be closed completely when burning wood. As with the combustor air control, turn counterclockwise to open and clockwise to close.

Damper Function

The **Damper** is operated by moving the small, square knob on the left side of the stove. It has two positions: open, to start or revive the fire; and closed for greatest efficiency and heat. Using the multipurpose door handle, rotate the damper knob counterclockwise to open the damper and clockwise to close it.

The stove damper must be open when starting a fire, when reloading fuel (for a short time only), and when the side or front doors of the stove are opened for any reason. It may also be left open when burning coal whenever maximum heat is needed.

Load Doors

The **Side Loading Door** allows the easiest loading of wood logs.

When the Sequoia is equipped with an 8" (200mm) flue collar, the Front Door may be utilized as well for loading coal or for adding an occasional log to wood fires. Also, the front door may be opened wide and an optional spark screen, Part No. 0135, placed in the opening for safe, fireplace-style viewing when burning wood. The front door must remain closed at all times when the 6" (150mm) flue collar is used.

With either flue size, the fire may still be viewed through the large ceramic viewing window when the front door is closed.

A Probe Thermometer Port Provides Access to Internal Temperatures

Insert the **Probe Thermometer** into the access port (see directions on Page 16) as a valuable guide that will tell you when to open and close the stove damper, when to increase or decrease the air supply, whether or not the stove's catalytic combustor is working properly when you are burning wood, and when to add fuel.

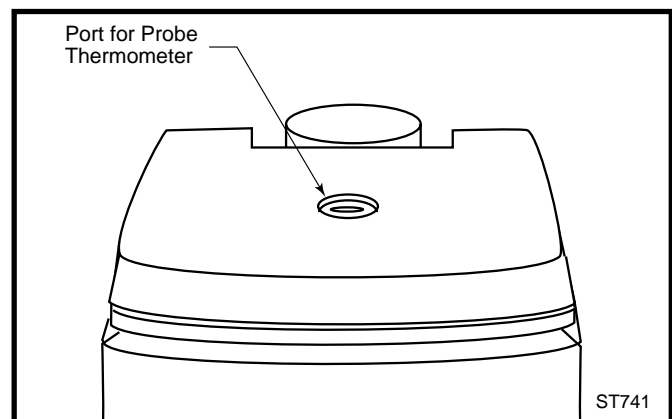

Fig. 19 The probe thermometer is a valuable guide to stove operation.

Successful Wood Burning

Burning wood and coal is often said to be more of an art than a science. You will easily master the art if you start by using good, dry fuel and by understanding how the stove's air supply system operates.

Burn Only High-Quality Fuel

This heater is designed to burn natural wood only (or coal, when the catalytic combustor has been removed and the optional coal kit installed). Do not burn fuels other than those for which this heater was designed. Never burn pressure-treated wood, painted or stained wood, or glossy newsprint.

High efficiencies and low emissions are possible when burning air-dried, seasoned woods as compared to softwoods or freshly cut hardwoods. Avoid burning "green" wood that has not been properly seasoned.

The best hardwood fuels include oak, maple, beech, ash, and hickory that has been split, stacked, and air-dried outside under cover for at least one year. If hardwood is not available, tamarack, yellow pine, white pine, Eastern red cedar, fir, and redwood are softwoods that are commonly burned. They too should be properly dried. The length of the wood should be the same as that specified for your particular stove. Avoid using wood that has been dried more than two years. Often gray in color, this wood burns very quickly, resulting in short burn time and diminished stove performance. If you must burn it, mix it in with greener wood to slow the burn. The length of the wood should be 23" (580mm).

When burning coal with the combustor removed, we recommend that you use only premium grade anthracite. Three sizes of coal are commonly burned: pea coal, a very small size averaging 3/8" to 3/4" (10-20mm); nut coal, a medium size of 3/4" to 1 1/2" (20-40mm); and stove coal, the largest size at 1 1/2" to 2 3/4" (40-70mm).

NOTE: Coal may be burned in the Sequoia only when the 8" (200mm) flue collar is used, and then only with optional coal kit #5531 installed.

Both wood and coal should be stored under cover to maintain dryness. Even for short-term storage, keep wood and coal a safe distance from the heater and keep it out of the areas around heater used for refueling and ash removal.

Use the Air Control Settings that Work Best for You

No single combination of control settings will fit every situation. Each installation will differ depending on the quality of the fuel, the amount of heat desired, and how long you wish the fire to burn.

Control settings also depend on your particular installation's "draft," or the force that moves air from the stove up through the chimney. Draft is affected by such things as the height, type, and location of the chimney, local geography, nearby obstructions, and other factors.

Too much draft may cause excessive temperatures in the stove. On the other hand, too little draft can cause backpuffing into the room and/or the "plugging" of the chimney and catalytic burner.

How do you know if your draft is excessively high or low? Symptoms of too much draft include an uncontrolled burn or a glowing-red part of the stove or chimney connector. A sign of inadequate draft is smoke leaking into the room through the stove or chimney connector joints.

In some newer homes that are well-insulated and weather-tight, poor draft may result from insufficient air in the house. In such instances, an open window near the stove on the windward side of the house will provide the fresh air needed.

Another option for getting more combustion air to the stove is to duct air directly from the outside to the stove. In fact, in some areas provisions for outside combustion air are required in all new construction.

Your Sequoia is designed to incorporate outside combustion air, and directions for installing an outside air duct may be found in the Assembly section.

When first using the stove, keep a record of the results you achieve from different control settings. You will find that specific control settings will give you a fixed amount of heat. It may take a week or two to determine the amount of heat and the length of burn you should expect from various control settings.

Most installations do not require a large amount of combustion air, especially if adequate draft is available.

Do not for any reason attempt to increase the firing of your heater by altering the air control adjustment range outlined in these directions.

Use the following air control settings as a starting point to help determine the best settings for your installation:

NOTE: To make the settings for these directions as clear as possible, imagine that the face of a clock is mounted behind the primary air control lever. Then, follow the directions to set the lever at the correct "time". (Fig. 20)

Sequoia Control Settings for Wood Fires

Burn Rate	Primary Air	Combustor Air
Low	6:00	1/2 turns
Medium	7:00	Fully Open
High	8:00 or greater	Fully open

(The coal-only control always remains closed, or rotated fully clockwise.)

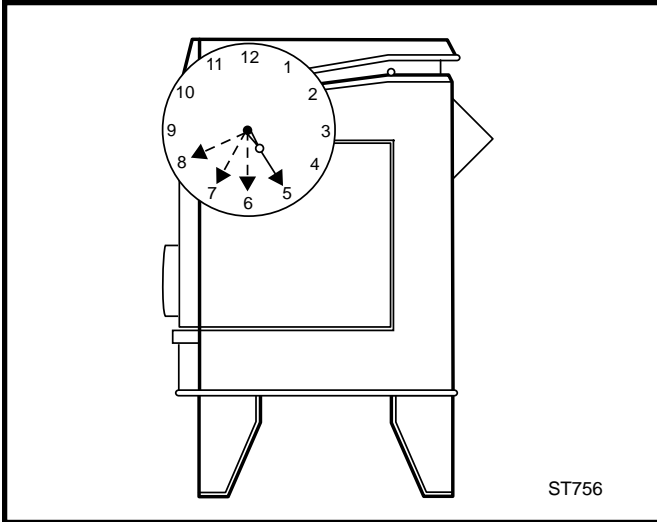

Fig. 20 The Sequoia's primary air supply is closed at the 5 o'clock position, and fully open at 8 o'clock or more.

Sequoia Control Settings for Coal Fires

(The primary air and combustor air controls always remain closed. Primary air is closed at the 5:00 position, while the combustor air is closed when rotated fully clockwise.)

Burn Rate	Coal-Only Air
Low	1/2 turn
Medium	1½ turns
High	Fully open

If your stove is equipped with an optional blower, it is important to follow these guidelines as well for best results:

At low-to-medium heat outputs, (a control setting of 6:00 to 7:00) the optional convection blower switch should be set on the "low" position, never on "high".

At higher heat outputs, (8:00 or more) the blower can be set on high if desired.

NOTE: The coal-only air control must always be closed during a wood fire. Likewise, the primary and combustor air controls must be close when burning coal.

DO NOT OPERATE THE STOVE WITH THE ASH DOOR OPEN. THIS CAN CAUSE EXTREME OVERFIRING OF THE STOVE, WHICH IS DANGEROUS.

The stove's paint and cement will emit a slight odor during the first few fires. We suggest that you provide extra ventilation near the stove by partially opening a door or window when the odor is present.

How to Build a Wood Fire and Keep it Going

Make sure your stove is set up correctly for burning wood.

A Sequoia leaves the factory with the catalytic combustor installed.

In the United States it is against the law to operate this wood heater in a manner inconsistent with the operating instructions in this manual, or if the catalytic combustor is deactivated or removed.

The grate covers are also installed. These are necessary for wood burning and should be left in place.

High-Efficiency Wood Burning with Catalytic Combustion

Smoke from a wood fire is really escaping energy that has not been burned to produce the heat. Combustion temperatures of 1100°F (595°C) are required to burn the smoke, and a level this high seldom is present in a fire set to burn several hours. As a result, long fires in conventional stoves lose a great deal of potential heat up the chimney as smoke.

A catalytic combustor captures this heat by lowering the temperature at which smoke will burn. This makes high efficiency possible even with long, low level fires.

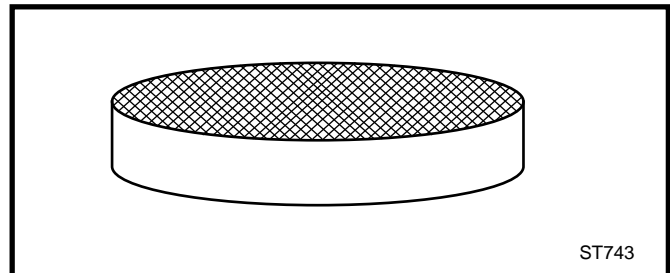

Fig. 21 High-efficiency performance when burning wood is a result of catalytic combustor that is coated with precious metals to cause smoke to burn at temperatures lower than normal.

Catalytic combustion is activated with two adjustments: by closing the stove damper, thereby exposing the smoke to the combustor, and by opening the combustor air control. The combustor needs extra air during medium and high burns, and the Sequoia's combustor air control must be fully open to supply it. During low burns, the combustor air control should be open only a 1/2 turn.

Closing the stove damper also reduces the draft, so to avoid putting out the fire or deactivating the combustor, close the damper only when a fire is well established. When starting a fire, wait until the fire is well established and there is an ember bed of at least two inches before closing the stove damper.

Never kindle a fire with colored paper or paper that has colored ink or a glossy surface, and never burn treated wood, garbage, solvents, or trash. All of these may poison the catalyst and prevent it from operating properly. Never burn cardboard or loose paper except for kindling purposes. This can cause smoke to spill into the room and effect the combustor operation. Coal smoke can also poison the catalyst so that it will not operate properly.

In general, the temperature in the stove and the gases entering the combustor must be raised to approximately 800°F (430°C) to ensure that catalytic activity is initiated. During the start-up of a cold stove, a medium-to-high-firing rate must be maintained for about twenty minutes. This ensures that the stove, catalyst and fuel are all stabilized at the proper operating temperatures.

Even though it is possible to have gas temperatures reach several hundred degrees within two to three minutes after a fire is started, the combustor may stop working or the fire may go out if the fire is allowed to die down immediately. Once the combustor starts working, heat generated by burning the smoke will keep it working.

The best operating range for the combustor is a reading of 1000-1400°F (540-760°C) on a probe thermometer. Temperatures over 1700°F (925°C) may damage the combustor.

To determine whether the combustor is operating, check the probe thermometer in the top of the stove. If it reads 800° (430°C) or higher, it is likely that the combustor is operating. If temperatures are lower than this, increase the intensity of the fire either by adding fuel or by increasing the amount of primary air.

Another way to tell if the combustor is working is to observe the amount of smoke leaving the chimney when the damper is activated and when it is not. This procedure is described on Page 25.

Conditioning Your Stove

Cast iron is extremely strong, but it can be broken with a sharp blow from a hammer or from the thermal shock of rapid and extreme temperature changes.

The cast plates expand and contract with changes in temperature. When you first begin using your Sequoia, minimize thermal stress by allowing the plates to adjust gradually during three or four initial break-in fires following Steps 1-3 below.

Starting and Maintaining a Wood Fire

Wood may be loaded into the Sequoia from either the front or the side. Loading from the front is useful for kindling a new fire or adding an occasional log, but we recommend side loading as the most convenient way of regularly adding several logs at a time.

When burning wood, your Sequoia may be operated with the front doors open, for fireplace-style viewing, as well as closed. The stove damper must be open and the **firescreen must be in place** whenever the door is open for fire viewing.

WARNING: For safety and greatest efficiency, operate your stove only with all doors fully closed. The test standard when the stove is operated in this mode is UL1482.

Your stove may be operated as a fireplace with the doors opened or removed only when equipped with an 8" (200mm) flue collar and only with the optional spark screen placed correctly in the opening to protect against the possibility of sparks and embers leaving the stove. The test standard for your stove when it is operated in this mode is UL737.

Use only the Sequoia spark screen, Part Number 0135, with your Sequoia. Sequoia spark screens are available from your Dutchwest authorized dealer.

1. Open the stove damper, and open the primary air control fully. Open the combustor air control two turns. The coal only air control must always be closed during wood burning.
2. Place crumpled newspaper in the stove. Do NOT use glossy advertisements or colored paper, as they can poison the catalyst. Place six or eight pieces of dry kindling split to a finger-width size on the paper, and on the kindling lay two or three larger sticks of split dry wood approximately 1-2" (25-50mm).

DO NOT USE CHEMICALS OR FLUIDS TO START THE FIRE. DO NOT BURN GARBAGE OR FLAMMABLE FLUIDS SUCH AS GASOLINE, NAPHTHA OR ENGINE OIL. Also, never use gasoline-type lantern fuel, kerosene, charcoal lighter fluid, or similar liquids to start or "freshen up" a fire in this heater. Keep all such liquids well away from the heater while it is in use.

3. Light the newspaper and close the door. Within 10-15 minutes the fire should be well established and you may gradually build up the fire by adding a few 3-5" (80-120mm) diameter splits. If this is one of the first few "break-in" fires, let the fire burn brightly, and then let it die out.

If the break-in procedure has been completed, continue building the fire until you have a live ember bed about 2" (50mm) thick.

You will soon find out that this stove is **HOT WHILE IN OPERATION! KEEP CHILDREN, CLOTHING AND FURNITURE AWAY. CONTACT MAY CAUSE SKIN BURNS.**

NOTE: Some chimneys, especially oversized or exterior chimneys, need to "primed", or warmed up, before they will draw sufficiently to start a fire. To

correct this situation, roll up a couple pieces of newspaper, place them on top of the kindling and toward the back of the stove, light them and close the doors. This should heat the chimney enough to initiate a draft.

Once the draft is established, open the front door and light the rest of the fuel from the bottom. Do not light the main bed of fuel until the chimney begins drawing, and repeat the procedure as often as necessary if the initial attempt is unsuccessful.

4. After the temperature on the probe thermometer has reached 450-500°F (232-260°C) (depending on your individual wood and draft situation), close the stove damper. This will activate the combustor. To ensure continued operation of the combustor, let the temperature approach at least 850°F (454°C) before reducing the air settings.
5. Close the primary air control to a medium setting, or about 6:00-7:00 on the imaginary clock face referred to on Page 18. The fire volume will diminish immediately, but the stove will continue to warm up. Maintain control of the fire using the primary air and combustor air controls, and remember: reduce the setting for a smaller fire, increase the setting for a larger fire. Refer back to the air control settings chart on Page 18 for recommended settings at different burn rates.

DO NOT OVERFIRE THIS HEATER. Overfiring may cause a house fire, or can result in permanent damage to the stove and to the catalytic combustor. If an exterior part of the stove or the chimney connector glows, you are overfiring.

Reloading and Reviving a Wood Fire

Open the stove damper and wait at least fifteen seconds for the draft to increase. Open the door slowly and add the fuel. Split wood will fill the firebox more completely and reduce the frequency of reloading.

Leave the stove damper open for a short time until the probe temperature reaches 800°F (430°C), then close it.

Frequently the temperature will drop below 800°F (430°C) after reloading, particularly if the loading door is open a long time. Should the temperature drop below this level, stimulate the fire by increasing the primary air supply while leaving the stove damper open. Reduce the air supply and close the stove damper when the temperature has reached 800°F (430°C).

NOTE: If the charcoal bed is relatively thick and your fuel is well-seasoned, it is possible to add fresh fuel (smaller pieces first), close the door and damper, and reset the air control within five minutes.

Draft is affected by a number of variables, such as outside temperatures and quality of fuel. Adjusting your

operation in response to these variables may be helpful. To maintain good draft under adverse conditions, refuel as often as necessary to keep the bed of the firebox covered with a 'robust' layer of hot coals. Run the stove at temperatures a little above minimum recommended temperatures.

Remove and Store Ash Safely

Wearing protective stove gloves, check the ash pan before reloading the stove. If the ash level is close to the top, empty the pan. Before replacing the ash pan, clear away any ash that has spilled over the sides and back of the pan.

When burning wood, empty the ash drawer regularly, typically every one to three days. The frequency will vary depending on how hot you run your stove: the hotter the fire, the more wood you burn, and the faster ash will accumulate.

Ash may contain hot coals and must be treated with extreme care.

Coal ash will accumulate rather quickly and will require emptying the ash drawer at least once a day. Empty it before shaking and reloading to allow the newly-shaken ash to cool before the next shakedown.

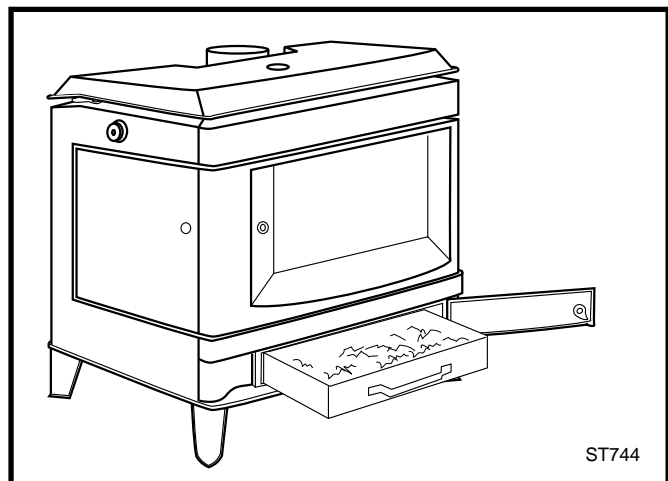

Fig. 22 Wear a heavy stove glove for protection when removing ash.

Always Dispose of Ash in a Safe Manner

Ash should be removed frequently and placed outdoors in a metal container with a tight-fitting lid. The closed container of ash should be placed on a noncombustible floor or on the ground, well away from all combustible materials, pending final disposal. If the ash is disposed of by burial in soil or otherwise locally dispersed, it should be retained in the closed container until all cinders have thoroughly cooled. Wood ash may be used as a garden fertilizer.

CAUTION: Never use a vacuum cleaner to remove ash from the stove; always remove and dispose of the ash properly.

Maintenance

Keep Your Stove Looking New And Working Its Best

Care of the Cast Iron Surface

An occasional dusting with a dry rag will keep the painted cast iron of your Sequoia looking new.

If the paint needs retouching, allow the stove to cool completely. Wire-brush areas needing to be painted. Remove non-painted components such as air controls or cover them with masking tape. Touch up the stove with high temperature stove paint available from your local dealer. Apply the paint sparingly. Two light coats are better than one heavy one.

To remove stains or spills from porcelain enamel, first make sure the stove is completely cool. Use a dry rag or soft brush, and use only a kitchen appliance cleaner or polish recommended for enamel surfaces.

Cleaning the Glass

Most of the carbon deposits on the glass will burn off regularly during hot fires. If you wish to clean the glass more thoroughly, follow this procedure:

- Be sure the glass is completely cool.
- Use a glass cleaner especially made for this purpose.
- Dry the glass completely.

Repair Air Leaks to Prevent Overheating

Self-Adjusting Door Latches

A tight seal of the doors ensures precision control over the firing rate, and prevents inadvertent overfiring. The self-adjusting design of your stove's door latch enables you to control the tightness of the seal each time you close the door.

To achieve greater tightness, turn the handle more in a clockwise direction. Each movement of the handle draws the door closer to the stove.

Do not use excessive force when tightening the door latch. A tight seal is made when only moderate pressure is applied to the handle.

Test and Repair the Door Gaskets

Air leaks can be caused by low spots in the door gaskets. To locate such low spots, close each door on a slip of paper and attempt to pull the paper free. If the paper slips out without tearing, the gasket is not snug enough at that spot.

If the seal cannot be improved by adjusting the door latch, try shimming the gasket. Pack a small quantity of

cement or a smaller diameter gasket into the channel beneath the gasket to lift the main gasket and thereby improve its contact with the door frame.

If shimming does not improve the seal, replace the gasket following these steps:

1. Remove the original gasket by grasping an end and pulling firmly.
2. Wearing safety goggles, use a wire brush or the tip of a screwdriver to clean the channel of any remaining cement or bits of gasket. (Fig. 23)

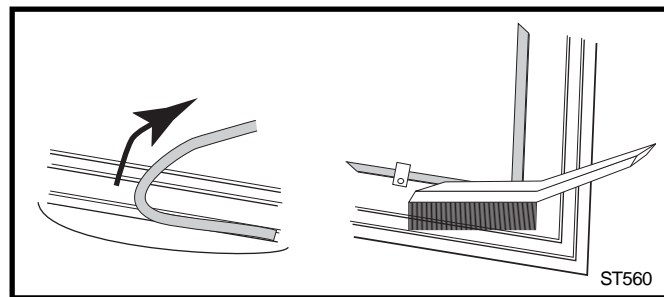

Fig. 23 Remove gasket then clean channel with wire brush.

3. Apply a thin bead of stove cement in the newly-cleaned groove. (Fig. 24)
4. Lay the gasket into the groove. Wait until you are a couple inches from the end before you cut it.

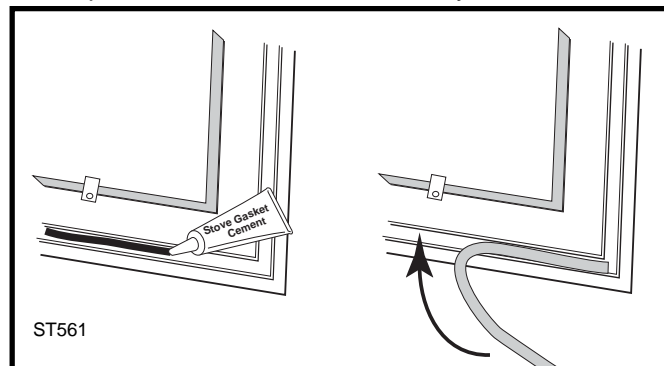

Fig. 24 Lay a bead of gasket cement then press gasket in place.

5. Test the gasket by closing the door on a slip of paper as described above. Adjust the gasket in any areas where an inadequate seal is evident. Allow the cement to dry 24 hours before firing your stove.

All rope-type gasketing used in the Sequoia is made of fiberglass. The gasket size for the front, side and ash doors, as well as for the top and inner top, is 3/8" diameter. The front door glass is sealed with a 3/16" gasket, while the flue collar employs a 1/4" size. Two small pieces of 1/4" wire gaskets are used inside the Sequoia between the grate seals and the left side plate, and a special Interam® gasket wraps around the combustor to provide a seal.

Repair Missing Cement in Seams

The cement in the stove seams may deteriorate over time and fall out in places. Just as with the stove doors, it is necessary to keep the seam seals in good condition. Spot-fix with furnace cement (available from your local dealer) any areas where the cement seal is visibly deteriorated. Allow 24 hours for the new cement to dry.

Avoid Damaging the Glass

Do not abuse the glass by slamming the door or striking the glass with a log. Never operate your stove if it has damaged or broken glass. If you need to replace the glass, use only replacement glass provided by your local Sequoia dealer.

Replace Broken Glass Immediately

Prepare to replace the glass in your stove by first clearing a large flat area nearby to use as a work surface. Place in order the pieces that you disassemble. This will be a great help when you put the pieces back together.

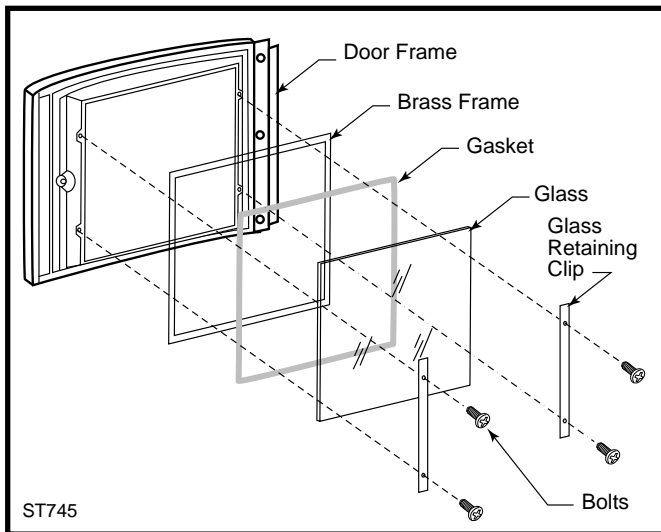

Fig. 25 In order of assembly, the front door glass components include a brass frame, gasket, glass, two clips and four bolts.

To remove the glass:

1. Open the front door. Lift the door gently while raising the end nearest you slightly. This will cause the bottom hinge pin to leave its seat. Once the bottom hinge pin is free, lower the door to free the top hinge pin. Place the door face down on a padded surface.
2. Remove the 7/16" bolts holding the stainless steel glass retaining clips on the left and right sides of the glass. Remove the clips and lift the glass off the brass frame. Lift broken glass carefully to avoid being cut.

3. Remove the old gasket.

To install the new glass:

1. Place a new piece of 3/16" gasket around the perimeter of the brass frame for the glass to rest on, as far to the outside as possible.
2. Place the new piece of glass on the gasket.
3. Position the glass retaining clips, and fasten in place with the 7/16" bolts previously removed. Tighten the bolts alternately. Do not over-tighten.

Damper Adjustment

Check the damper to confirm that it is locking tightly whenever the top is removed for combustor inspection. If the damper needs adjustment, use a 7/16" socket wrench with a socket extension and follow this procedure:

1. Remove the stove top plate. It is held in place by two bolts. these bolts are accessible when you open the front door and look upward toward the underside of the top plate. Remove the two bolts. **NOTE:** The left hand bolt is more accessible through the side door.
2. Lift the top plate off the stove. It is heavy, you may choose to have a helper assist you.
3. Open the damper.
4. If necessary for better access, carefully remove the refractory cover.
5. Loosen the adjusting bolt's lock nut.
6. Loosen the anchor bolt's lock nut located on the back side of the damper and accessible inside the stove through the front door.
7. Loosen the anchor bolt a turn or two.
8. Tighten the adjusting bolt.

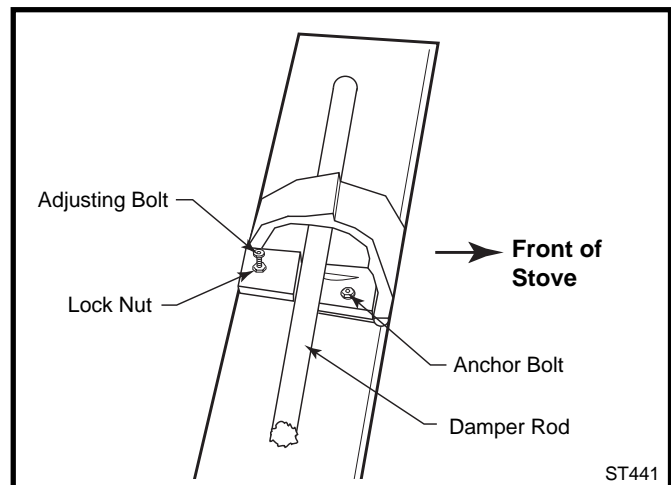

Fig. 26 Damper adjustment.

9. Test the damper mechanism. If further adjustment is necessary, continue to tighten the adjusting bolt until the damper closes snugly.
10. When final adjustment has been made, tighten the adjusting bolt lock nut.
11. Tighten the anchor bolt. Tighten the anchor bolt lock nut.
12. Replace the top.

Care of the Catalytic Combustor

This wood heater contains a catalytic combustor, which needs regular inspection and periodic replacement for proper operation. Reminder: It is against the law in the United States to operate this wood heater in a manner inconsistent with operating instructions in this manual, or if the catalytic element is deactivated or removed.

Under normal operating conditions, the catalytic combustor should remain active for two to six years (depending on the amount of wood burned). However, it is important to monitor the combustor periodically to ensure that it is functioning properly, as well as to determine when it needs to be replaced. A non-functioning combustor will result in a loss of heating efficiency, and an increase in creosote and emissions.

The combustor should be visually inspected "in place" for fly ash accumulation and physical damage three times per year. Actual removal of the combustor is not recommended unless a more detailed inspection is warranted because of diminished performance as outlined below.

The refractory package that housed the catalytic combustor should be inspected annually for a buildup of fly ash and cleaned if necessary. This may be done during examination of the catalytic combustor.

When to Suspect a Combustor Problem

There are two ways to evaluate the performance of your stove's combustor. The first is to monitor the temperatures recorded on the probe thermometer. A properly functioning combustor should operate regularly in the range of 800-1200°F (430-650°C). Combustor temperatures consistently less than 800°F (430°C) are a sign that examination of the combustor is advisable.

The second performance test is to observe the amount of smoke leaving the chimney - both when the combustor has achieved "light-off" and when it has not. Follow this simple two-step procedure:

- With a fire in the stove and damper closed to activate the combustor, go outside and observe the smoke leaving the chimney.
- Then, open the stove damper and once again observe the smoke leaving the chimney.

Significantly more smoke should be observed after the second step when the stove damper is open and exhaust is not routed through the combustor. Be careful not to confuse smoke with steam from wet wood, however!

If either of these tests indicates a problem, consider other possible factors as well.

Assess your present operating conditions. In spring or fall, draft is weaker than it is in colder winter weather, and a related change in stove performance may result. Small hot fires are a good solution to sluggish performance under these conditions.

Burning "green" (insufficiently seasoned) wood will result in poorer performance than when burning properly seasoned fuel. You may have to run your stove hotter (more air) to achieve good performance if you are burning green or wet wood. Also, any changes in operating routine should be considered at this time as a possible reason for changed performance.

Once you have ruled out any other possible causes for a decline in performance, you may proceed with an inspection of the catalyst.

Remove and Inspect the Combustor

Before you begin, observe the basic safety precautions for working with dusty materials: always wear safety glasses, a dust mask and gloves.

- Remove the stove top plate. It is held in place by two bolts. One bolt is accessible when you open the front door and look upward toward the underside of the top plate. The other bolt is most easily reached through the side loading door. Remove the two bolts.
- Lift the top plate off the stove. It is heavy, and you may choose to have a helper assist you.
- The combustor is located beneath the removable refractory package, directly below the stove top near the center of the stove.

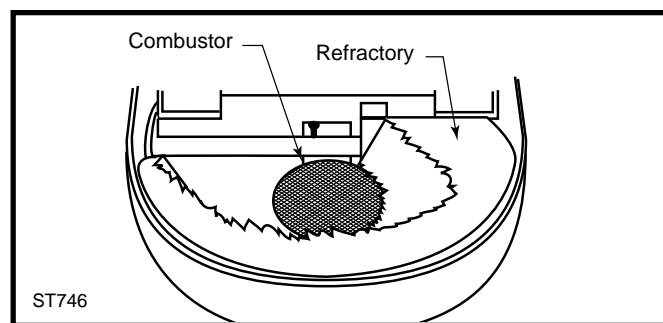

Fig. 27 A cutaway view of the combustor and its refractory cover.

- Carefully remove the refractory package. It is extremely delicate and should be handled as little as possible.

- For a visual inspection for blockage that can be performed without removing the combustor, have an assistant shine a bright flashlight beam up through the combustor from inside the stove's firebox.
 - If combustor removal is necessary for cleaning or closer inspection, lift it gently out of its chamber.
- NOTE:** Have a replacement Interam gasket available before removing the combustor.
- Check the combustor and the bottom of the refractory chamber for a buildup of fly ash, and remove any ash by gently blowing air through the combustor. Do not brush the surface, as this could damage the element.
 - Inspect the combustor, referring to the information in the "Catalytic Combustor Appendix" on Page 28 for information on what to look for. Although small hairline cracks will not affect performance, the combustor should be essentially intact. If the combustor is broken in pieces or has sections missing, it should be replaced. Call your local Dutchwest dealer for a replacement combustor, item #CB56. Consult the warranty section at the back of this manual for further information on catalytic combustor replacement.
 - If the combustor is in good condition and clean, reinstall it. Be sure first to carefully wrap a new Interam® gasket (an extra was provided with your stove) around its perimeter before replacement. Insert the gasketed combustor back into position, and replace the refractory package.
 - Before replacing the stove top, check the damper. If the gasket is intact, but the damper is not locking tightly, adjustment should be made. Directions for adjusting the damper are on Page 24. Also check the gasket that seals the top plate.
 - Gasket should be replaced only if damaged or missing. The top plate and gasket both are sealed with a 3/8" gasket. The procedure for removing the old gasket and installing the new is the same as that described for door gaskets on Page 23.
 - Replace the stove top, and secure it by tightening the two top plate bolts from inside the firebox. Be sure the top plate seats properly before tightening. Tighten the bolts gradually and alternately.

Watch for Better Results

Finish up by cleaning the chimney and chimney connector. Then, operate the stove in a typical manner for two weeks and observe the stove's performance, taking particular note of the performance tests described above.

If a problem persists, contact your local dealer for further advice about your particular situation.

A Clean Chimney System is Safer and Works Better

Learn to Recognize Creosote and Soot

When you first begin using the stove, check daily for creosote - a substance that can look like either thick tar or black, crisp flakes. Experience will show how often you need to clean to be safe. The frequency may even vary during the year. In the colder months when the hottest fires producing the least creosote are burned, you may need to clean less frequently. During the warmer months when creosote is more likely to result from cooler-burning fires, more frequent cleaning may be necessary.

At the very least, inspect the chimney and chimney connector twice monthly. Clean if necessary. Let the stove cool to determine if a buildup of creosote or soot has occurred. If a significant layer of creosote has accumulated (1/8" [3mm]), or if soot has built up, either should be removed to reduce the risk of a chimney fire. Failure to keep the chimney and connector system clean can result in a serious chimney fire.

The conditions for a chimney fire develop like this: When wood is burned slowly, it produces tar and other organic vapors, which combine with expelled moisture to form creosote. The creosote vapors condense in the relatively cool chimney flue of a slow-burning fire. As a result, creosote residue accumulates on the flue lining. When ignited, this creosote makes an extremely hot fire within the flue system which can damage the chimney and overheat adjacent combustible material.

To reduce the amount of creosote that may form, remember to provide adequate air for combustion and to strive for small, intense fires rather than large, smoldering ones.

Coal fires cause soot, which requires removal as well. When coal is burned, the products of combustion combine with moisture to form a soot residue which accumulates in the flue lining. When ignited, this soot makes an extremely hot fire.

You can never be too safe. Contact your local fire authority for information on what to do in the event of a chimney fire, and have a clearly defined plan on how to handle one.

Inspect Chimney Connector and Chimney Twice Monthly and Clean as Required

Let the stove cool completely before you inspect the chimney. Then, using a strong light, sight up through the flue collar into the chimney flue. If it is not possible to inspect the flue system in this fashion, the stove must be disconnected to provide adequate viewing.

Clean the chimney using a specially designed chimney cleaning brush, the same size and shape as the flue liner, attached to flexible fiberglass rods designed for this purpose. Run the brush up and down the liner so that any deposits fall to the bottom of the chimney where they can be removed through the clean-out door. The chimney connector should be cleaned by disconnecting the sections, taking them outside, and removing any deposits with a stiff wire brush. Reinstall the connector sections after cleaning, being sure to secure the individual sections with three sheet metal screws per section.

If you are unable to inspect and/or clean the chimney system yourself, contact your local dealer or hire a qualified chimney sweep in your area to do the job.

Maintenance Schedule

DAILY:

- Ashes should be removed before they reach the top of the ash pan. Check at least once a day.
- Keep the area around the stove clear of any combustible materials.

TWO WEEKS

- Inspect the chimney and chimney connector. Pay particular attention to the horizontal runs of chimney connector and the elbows. Clean the system if necessary.

TWO MONTHS:

- Inspect the catalytic combustor. Clean if necessary.
- Check door handle to be sure it is sealing properly. Gaskets become compressed after a period of time and the tight seal may be lost. Check that the door latch is firmly attached to the door shaft. If necessary, seat the latch firmly on the shaft and retighten the set screw on the door latch.
- Check leg bolts and heat shield screws; tighten if necessary.

Annual Spring Cleaning

- Check gaskets for wear, and replace if necessary.
- Remove ashes from the ash pan and replace with a moisture absorbing material (such as kitty litter) to keep the interior of the stove dry.
- Inspect and clean the refractory package.
- Clean the dust from the inner sides of bottom, rear or pipe heat shields if your stove is equipped with them. Clean surfaces are better heat reflectors than dirty surfaces.
- Touch up the black paint on non-enamel stoves.

- Disassemble the chimney connector and take it outdoors for inspection and cleaning. Replace weak sections of connector.
- Inspect the chimney for signs of deterioration. Repairs to a masonry chimney should be made by a professional mason. Replace damaged sections of prefabricated chimney. Your local dealer or a chimney sweep can help determine when replacement is necessary.
- Thoroughly clean the chimney.

Catalytic Combustor

In any chemical reaction, including the combustion process, there are certain conditions which must be met before the reaction can take place. For example, a reaction may require a certain temperature, or a certain concentration of the reactants (the combustion gases and oxygen), or a certain amount of time. Catalysts, though not changed themselves during the reaction, have the ability to act at a molecular level to change these requirements. In the secondary combustion chamber of the Sequoia, the catalyst reduces the temperature at which secondary combustion can start from the 1000 - 1200°F. (540 - 650°C) range to the 500 - 600°F. (260 - 315°C) range, increasing efficiency, and reducing creosote and emissions.

Though it is advantageous, the catalytic reaction does have some limitations of its own. Primary among these is that the reactants (the gases) come into close physical contact with the catalyst itself.

To ensure the necessary contact, the catalytic element in your Sequoia is composed of a ceramic base in the shape of a honeycomb. On each of the honeycomb's many surfaces a coating of the catalyst (usually a noble metal such as platinum or palladium) is applied. The large surface area exposed in this configuration ensures that the combustion gases have the greatest opportunity to come in contact with the catalyst.

Loss of catalytic activity will be apparent in several ways. First you may notice an increase in fuel consumption. Second, there will be a visible increase in the rate at which creosote builds up in your chimney connector system. You may also notice a heavy discharge of smoke from the chimney. There are a number of catalytic problems which can cause loss of activity:

Blockage

While the honeycomb pattern ensures good contact, it also increases the resistance to flow of the combustion gases, and, because of the many surfaces, provides more places for creosote and fly ash to deposit. It is important to follow the operating instructions in order to minimize these deposits, and to periodically inspect your catalyst for signs of blockage.

Masking and Poisoning

While the catalyst itself does not enter into the combustion process, it is possible for certain elements, such as lead and sulfur, to attach to the active sites on the surface of the honeycomb. Though the catalyst is still there, it is covered, or masked, by the contaminant, and cannot function. To avoid this situation, it is important not to burn anything in your Sequoia that is a source of these contaminants. Particularly avoid painted or treated wood, coal, household trash, colored papers, metal foils, or plastics. Chemical chimney cleaners may also contain harmful elements. The safest approach is to burn only untreated, natural wood.

Flame Impingement

The catalytic element is not designed for exposure to direct flame. If you continually overfire your Sequoia, the chemistry of the catalyst coating may be altered, inhibiting the combustion process.

Thermal degradation of the ceramic base may also occur, causing the element to disintegrate. Stay within the recommended guidelines of the Operation section.

Mechanical Damage

If the element is mishandled, damage may occur. Always treat the element carefully. Remember the catalyst is made of a ceramic material; treat it as you would fine china. Hairline cracks will not affect the performance of the catalyst, as long as the steel sleeve holds the element in the proper position.

Peeling

Peeling of the surface coat may occur if the catalytic element is frequently subjected to excessive temperatures. Follow the operating instructions carefully to avoid this type of damage.

Every Dutchwest product is equipped with either a Corning "Long-Life"® or a Technical Glass Products "Honeycomb"®. The products are equivalent. If for any reason you must ship your catalytic element, remember its fragile nature. Place the element in a plastic bag, and package it with a generous amount of shock absorbing material.

Draft Management

Your stove is only one part of a system that includes the chimney, the operator, the fuel, and the home. The other parts of the system will affect how well the stove works. When there is a good match between all the parts, the system works well.

Wood stove operation depends on natural (unforced) draft. Natural draft occurs when exhaust gas is hotter (and therefore lighter) than the outdoor air at the top of the chimney. The greater the temperature difference, the stronger the draft. As the hot exhaust gas rises out of the chimney, it generates suction that draws air into the stove for combustion. A slow, lazy fire when the stove's air inlets are fully open indicates a weak draft. A brisk fire, supported only by air entering the stove through the air inlets, indicates a good draft. The inlets are passive; they regulate how much air *can* enter the stove, but they don't force air into it.

The efficiency of a modern woodburning appliance, (in which the amount of air available for combustion is regulated), depends on the chimney to keep exhaust gases warm all the way outdoors. The characteristics of your chimney - whether it is steel or masonry, interior or exterior, matched or mismatched to the stove outlet, - determine how quickly it will warm up and how well it will sustain the optimum temperatures necessary to maintain strong draft and efficient combustion. Here follows a description of various flue system characteristics and the related effects on stove performance.

Masonry Chimney

Although masonry is the traditional material used for chimney construction, it can have distinct performance disadvantages when used to vent a controlled-combustion woodstove. Masonry forms an effective 'heat sink' - that is, it absorbs and holds heat for long periods of time. The large mass, however, may take a long time to become hot enough to sustain a strong draft. The larger the chimney (in total mass), the longer it will take to warm up. Cold masonry will actually cool exhaust gases enough to diminish draft strength. This problem is worse if the chimney is located outside the home or if the chimney flue has a cross-sectional volume much larger than the stove outlet.

Steel Chimney

Most factory-made 'Class A' steel chimneys have a layer of insulation around the inner flue. This insulation keeps the smoke warm and protects the surrounding structure from the high flue temperatures. Because the insulation is less dense than masonry, the inner steel liner warms up more quickly than a masonry chimney; this makes the steel chimney support a good draft more quickly than masonry does. Steel chimneys are not as attractive as masonry, but they are very durable and generally outperform masonry.

Indoor/ Outdoor Location

Because the chimney's function is to keep the smoke warm, it is best to locate it inside the house. This location uses the house as insulation for the flue and allows some radiant heat release from the flue into the home. Since an interior chimney doesn't continuously lose its heat to the outdoors, less heat from the stove is required to get it warm and keep it warm.

Flue Sizing

The flue size for a controlled-combustion appliance should be based on the cross-sectional volume of the stove flue outlet. In this case, more is definitely not better. Hot gases lose heat through expansion; if a stove with a six-inch flue collar (28 square inch area) is vented into a 10" x 10" flue, the gases will expand to over three times their original volume. As gases cool with expansion, draft strength decreases. If an oversized flue is also outside the house, the heat it absorbs will be conducted to the outdoor air and the flue will remain relatively cool.

It is common for a masonry flue to be oversized for the stove. Such a chimney can take quite a while to warm up and the stove performance will likely be disappointing. The best solution to an oversize flue problem is the installation of an insulated steel chimney liner of the same diameter as the appliance flue outlet. The liner keeps the exhaust gas warm and the result is a stronger draft. An uninsulated liner is a second choice - although the liner will keep the exhaust restricted to its original volume, the air around the liner will require time and heat energy to warm up.

Check your local codes. You may be required to install a flue liner in any oversize or masonry flue.

Pipe & Chimney Layout

Every bend in the flue will act as a brake on the exhaust as it flows from the firebox to the chimney cap. The ideal pipe and chimney layout is straight up from the stove through a completely straight chimney. Use this layout if at all possible as it will promote optimum stove performance and simplify maintenance.

If the stovepipe must elbow to enter a chimney, locate the elbow about midway between the stove top and the chimney thimble. This configuration lets the smoke speed up before it must turn, keeps some pipe in the room for heat transfer, and allows long-term flexibility for installing a different appliance without relocating the thimble.

There should be no more than eight feet of single-wall stove pipe between the stove and a chimney. Longer runs can cool the smoke enough to cause draft and creosote problems.

Single Venting

Your stove requires a dedicated flue. Do not connect the stove to a flue used by any other appliance. Chimney draft is a natural form of energy and follows the path of least resistance. If the stove is vented to a flue that also serves an open fireplace or another appliance, the draft will also pull air in through those avenues. The additional air flow will lower flue temperatures, reduce draft strength and promote creosote development; overall stove performance will suffer. The effect is similar to that of a vacuum cleaner with a hole in the hose. In some extreme instances, the other appliance can even impose a negative draft and result in a dangerous draft reversal.

Fuel

Even the best stove installation will not perform well with poor fuel. If available, always use hardwood that has been air-dried ("seasoned") 12-18 months. Softwood burns more rapidly than hardwood and has a high pitch content conducive to creosote production. Decayed wood of any type has little heat value and should not be used.

All unseasoned ('green') wood has a high moisture content. Much of its heat value will be used to evaporate moisture before the wood can burn. This significantly reduces not only the amount of energy available to warm your home, but also the intensity of the fire and temperature of the exhaust gas. Incomplete combustion and cool flue temperatures promote creosote formation and weak draft.

You can judge the moisture content of wood by its appearance and weight or use a commercially available moisture meter for an exact measurement. Unseasoned wood will be a third heavier than dry wood. Also, look for cracks ("checking") in the ends of the log that result from contraction as the wood dries. The longer and wider the cracks are, the dryer the wood is.

Purchase your fuel from a reputable dealer.

Creosote

Creosote is a by-product of low-temperature stove operation, weak draft, or both. It is a tar that results when unburned gases condense inside the flue system at temperatures below 290° F. Creosote is volatile and can generate a chimney fire. All of the installation characteristics that adversely affect chimney draft also promote creosote condensation. Consequently, you can minimize creosote accumulation with an effective chimney design and the use of operational techniques that encourage good draft and complete combustion.

Inspect your chimney frequently and clean it whenever accumulation exceeds 1/4".

Backpuffing

Backpuffing is a condition that results when the draft is too weak to pull flue gases out of the chimney system as

fast as the fire generates them. Volatile gases build up within the firebox until reaching a density and temperature at which they ignite. With this ignition, you may hear a muffled popping sound and see a bit of smoke forced out of the stove.

This condition is most likely to occur in the Spring or Fall when moderate outdoor temperatures and low intensity fires produce weak draft. If your stove back-puffs, open up the damper to let the smoke rise to the flue more quickly. Also, open the air inlets to induce a livelier fire and speed airflow through the stove. Avoid large loads of firewood at one time. You should always see lively, dancing flames in the firebox; a lazy, smoky fire is inefficient and will promote draft problems.

Draft Testing

An easy way to determine whether your chimney draft is strong enough is to close the stove damper, wait a few minutes to let the airflow stabilize, and then test whether you can vary the strength of the fire by swinging the air control open and closed. Results here are not instant; you may need to wait a few minutes for a change in the air control setting to have an effect on the fire. If there is no change, the draft is not yet strong enough to let you close the damper. You will need to open it for a while longer and manage the fire with the air inlet until the draft strengthens. Keep a record of your operating habits and relate them to their effects on the stove's function. You'll be rewarded with safe and efficient performance.

Negative Pressure

Good draft also depends on a sufficient supply of air to the stove. The chimney can't pull in more air than is available to it. Sluggish draft can be caused by a house that is tight enough to prevent the ready flow of air to the stove, or by competition between the stove and other appliances that vent indoor air to the outside; i.e., exhaust fans for range hoods, clothes dryers, bathroom fans, etc. If the chimney draws well when all such equipment is turned off (or sealed, in the case of fireplaces and/or other stoves), you need to be attentive in timing the use of the other appliances. If you need to crack a nearby window or door to enable the chimney to pull well, you should install an outside-air intake to bring combustion air into the room.

Conclusion

Woodburning is more an art than a science. Art includes technique; and since installations, homes, and fuel vary, the stove operator must also vary technique, (mostly timing), to achieve satisfying results. Over time, you will become familiar with the features of your particular installation; you will be able to identify cause and effect in a variety of seasonal circumstances, and adapt your operating habits to changing conditions.

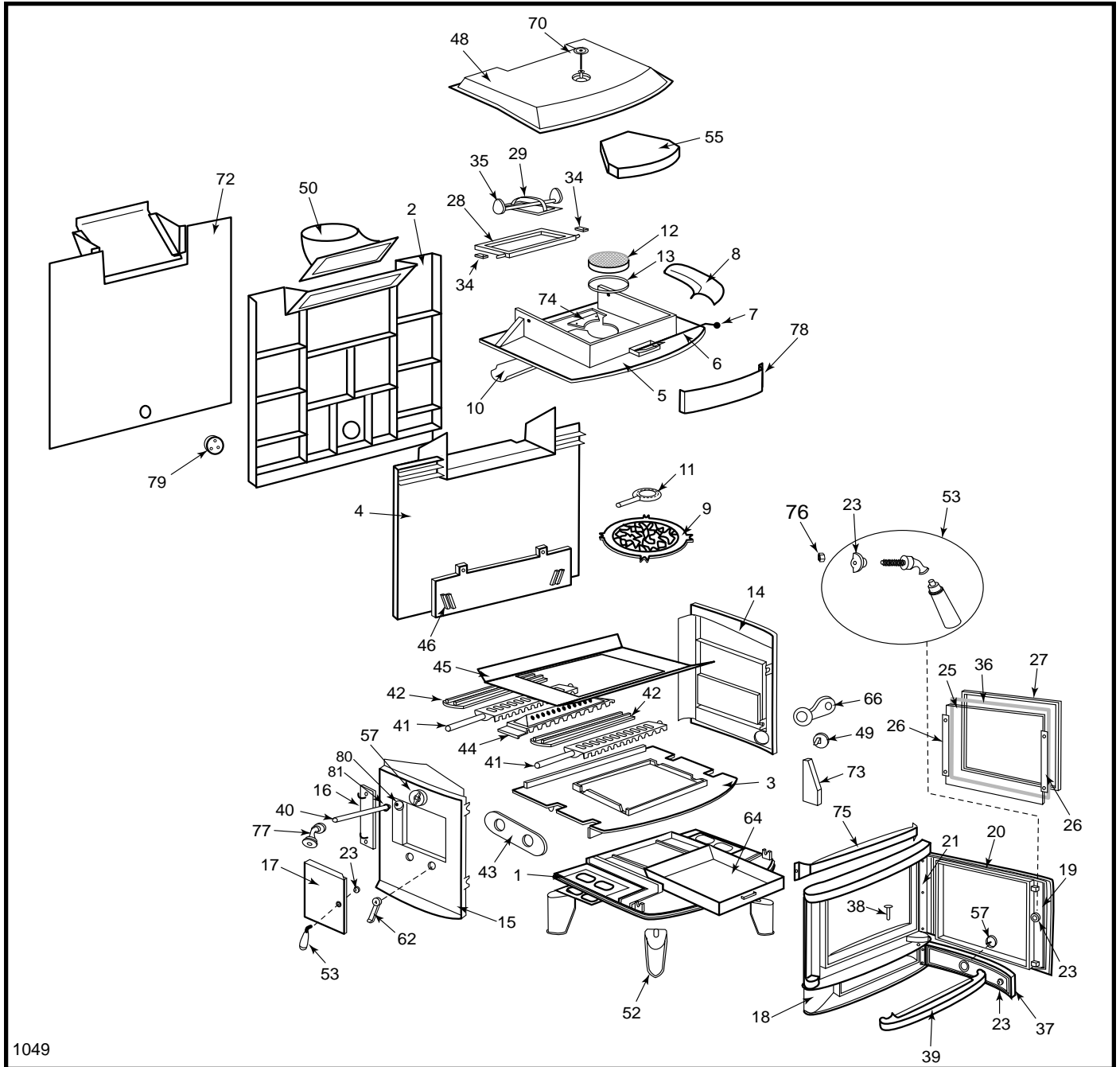

1049

CFM Specialty Home Products reserves the right to make changes in design, materials, specifications, prices and discontinue colors and products at any time, without notice.

Sequoia Woodburning Stove

Model 2160

Item Description	Part Number
1. Bottom	7000992
2. Back	7000993
3. Bottom, Inner	7000994
4. Back, Inner	7000995
5. Top II, Inner*	7001115
6. Valve, Air	7001009
7. Ball, Gold	1602470

Item Description	Part Number
8. Tube, Outside Air	7001005
9. Baffle	7000953
10. Channel Cap, Inner Top	7001007
11. Air Distributor S/S	7000952
12. Combustor, Catalytic	700B566
13. Gasket, Interam - 6" Dia.	1203533
14. Side, Right	7000997

Sequoia Woodburning Stove Model 2160 (continued)

Item Description	Part Number
15. Side, Left	7000996
16. Plate, Side Door Hinge	700G808
17. Door, Side	7001001
18. Front, Sequoia	7000998
19. Door, Front	7001002
20. Gasket, Fiberglass 3/8 - Low D, 6ND	1203589
21. Hinge, Front Door Upper	700G806
23. Latch, Door w/Set Screw	7000836
24. SS. Soc 5/16 - 18 x 5/16 Blk	1200563
25. Glass	7001011
26. Retainer. Glass	7001012
27. Trim, Glass - Brass	7001013
28. Bypass Gate	7000954
29. Adjuster, Bypass	7000950
34. Tab, Damper	1601488
35. Crank, Bypass Gate	7000951
36. Gasket, Fiberglass 3/16 4ND Blk	1203556
37. Ashdoor	7000820
38. Pin, Hinge - Ash Door	1201837
39. Hearth	7001100
40. Rod, Operating - Bypass Gate	7001131
41. Grate, Rocker	7001092
42. Cover, Shaker Grate	7000803
43. Seal, Grate	7001090
44. Grate, Fixed Section	7000802

Item Description	Part Number
45. Frame, Grate	7000999
46. Back, Grate	7000808
48. Top	7001000
49. Fan Plate, Brass	1406063
50. Flue Collar (6" Diameter)	1305050
Flue Collar (8" Diameter)	1304280
52. Leg - 6"	7000829
53. Handle Assy - Vert. Align Gold	5004271
55. Refractory	1602515
57. Dial Damper, Brass - LG	7000011
62. Grate Tool, Shaker	7000835
64. Ashpan	700G802
66. Blower (Optional)	0009973
70. Thermometer, Cat. Probe	0000948
72. Rear Heat Shield (Optional)	0001060
73. Andiron (Optional)	7001008
74. Inner Top Web*	7001110
75. Air Manifold	7001006
76. Nut, Hex Jam 3/8-16 TOPLK-Z	1203290
77. Damper Handle Stub w/Screw - Gold	5004267
78. Divider, Air	30001900
79. Plate, Fan	7000831
80. 5/8 I.D. Washer	1202561
81. Retaining Ring, E Style s/s	1203058

Warranty

Limited 3 Year Warranty

CFM Specialty Home Products warrants that this woodburning stove will be free of defects in material and workmanship for a period of three years from the date you receive it, except that the catalyst, thermostat assembly, handles, glass door panels, cement, and gasketing shall be warranted as described below.

Products will repair or replace, at its option, any part found to be defective upon inspection by a CFM Specialty Home Products Authorized Dealer. The customer must return the defective part or the stove, with shipping prepaid, to the Authorized Dealer or pay for any Authorized Dealer in-home travel fees or service charges for in-home repair work. It is the dealer's option whether the repair work will be done in the customer's home or in the dealer's shop. If, upon inspection, the damage is found to be the fault of the manufacturer, repairs will be authorized at no charge to the customer for parts and/or labor.

Any woodburning stove or part thereof that is repaired or replaced during the limited warranty period will be warranted under the terms of the limited warranty for a period not to exceed the remaining term of the original limited warranty or six (6) months, whichever is longer.

Limited 1 Year Warranty

The following parts of the woodburning stove are warranted to be free of defects in material and workmanship for a period of one year from the date you receive it: The thermostat assembly, handles, glass door panels, cement, and gasketing. Any of these items found to be defective will be repaired or replaced at no charge, upon the return of the part with postage prepaid to a CFM Specialty Home Products Authorized Dealer.

Any part repaired or replaced during the limited warranty period will be warranted under the terms of the limited warranty for a period not to exceed the remaining term of the original limited warranty or six (6) months, whichever is longer.

Exclusions & Limitations

1. This warranty is transferable; however, proof of original retail purchase is required.
2. This warranty does not cover misuse of the this stove. Misuse includes overfiring which will result if the stove is used in such a manner as to cause one or more of the plates to glow red. Overfiring can be identified later by warped plates and areas where the paint pigment has burned off. Overfiring in enamel fireplaces is identified by bubbling, cracking, chipping and discoloration of the porcelain enamel finish. CFM Specialty Home Products offers no warranty on chipping of enamel surfaces. Inspect your woodburning stove prior to accepting it for any damage to the enamel.
3. This warranty does not cover misuse of the stove as described in the Owner's Guide, nor does it cover any stove which has been modified unless authorized by a CFM Specialty Home Products representative in writing. This warranty does not cover damage to the stove caused by burning salt saturated wood, chemically treated wood, or any fuel not recommended

in the Owner's Guide.

4. This warranty does not cover a stove repaired by someone other than a CFM Specialty Home Products Authorized Dealer.

5. Damage to the unit while in transit is not covered by this warranty but is subject to a claim against the common carrier. Contact CFM Specialty Home Products Authorized Dealer from whom you purchased your stove or CFM Specialty Home Products if the purchase was direct. (Do not operate the stove as this may negate the ability to process the claim with the carrier.)

6. Claims are not valid where the installation does not conform to local building and fire codes or, in their absence, to the recommendations in our Owner's Guide.

7. The salt air environment of coastal areas, or a high-humidity environment, can be corrosive to the porcelain enamel finish. These conditions can cause rusting of the cast iron beneath the porcelain enamel finish, which will cause the porcelain enamel finish to flake off. This warranty does not cover damage caused by a salt air or high-humidity environment.

8. CFM Specialty Home Products shall have no obligation to enhance or update any unit once manufactured.

IN NO EVENT SHALL CFM SPECIALTY HOME PRODUCTS BE LIABLE FOR INCIDENTAL AND CONSEQUENTIAL DAMAGES. ALL IMPLIED WARRANTIES, INCLUDING THE IMPLIED WARRANTIES OF MERCHANTABILITY AND FITNESS, ARE LIMITED TO THE DURATION OF THIS WRITTEN WARRANTY. THIS WARRANTY SUPERCEDES ALL OTHER ORAL OR WRITTEN WARRANTIES.

Some states do not allow the exclusion or limitations of incidental and consequential damages or limitations on how long an implied warranty lasts, so the above limitations may not apply to you. This warranty gives you specific rights and you may have other rights which vary from state to state.

How to Obtain Service

If a defect is noted within the warranty period, the customer should contact a CFM Specialty Home Products Authorized Dealer or CFM Specialty Home Products if the purchase was direct with the following information:

1. Name, address, and telephone number of the purchaser.
2. Date of purchase.
3. Serial number from the label on the back.
4. Nature of the defect or damage.
5. Any relevant information or circumstances, e.g., installation, mode of operation when defect was noted.

A warranty claim will then start in process. CFM Specialty Home Products reserves the right to withhold final approval of a warranty claim pending a visual inspection of the defect by authorized representatives.

CFM Specialty Home Products

410 Admiral Blvd. • Mississauga, Ontario, Canada L5T 2N6 • 905-670-7777
www.majesticproducts.com • www.vermontcastings.com